

Ray Optics and Optical Instruments

Question1

A convex lens of focal length 40cm forms an image of an extended source of light on a photoelectric cell. A current I is produced. The lens is replaced by another convex lens having the same diameter but focal length 20cm. The photoelectric current now is :

[27-Jan-2024 Shift 1]

Options:

A.

$I/2$

B.

$4I$

C.

$2I$

D.

I

Answer: D

Solution:

As amount of energy incident on cell is same so current will remain same.

Question2

If the refractive index of the material of a prism is $\cot(A/2)$, where A is the angle of prism then the angle of minimum deviation will be

[27-Jan-2024 Shift 1]

Options:

A.

$\pi - 2A$

B.

$\pi/2 - 2A$

C.

$\pi - A$

D.

$\pi/2 - A$

Answer: A

Solution:

$$\cot \frac{A}{2} = \frac{\sin \left(\frac{A + \delta_{\min}}{2} \right)}{\sin \frac{A}{2}}$$

$$\Rightarrow \cos \frac{A}{2} = \sin \left(\frac{A + \delta_{\min}}{2} \right)$$

$$\frac{A + \delta_{\min}}{2} = \frac{\pi}{2} - \frac{A}{2}$$

$$\delta_{\min} = \pi - 2A$$

Question3

Two immiscible liquids of refractive indices $8/5$ and $3/2$ respectively are put in a beaker as shown in the figure. The height of each column is 6cm . A coin is placed at the bottom of the beaker. For near normal vision, the apparent depth of the coin is $\alpha/4$ cm. The value of α is _____

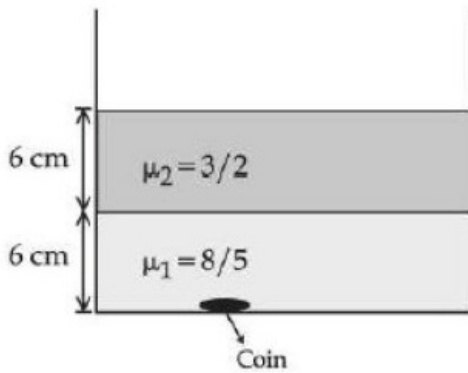

[27-Jan-2024 Shift 1]

Answer: 31

Solution:

$$h_{\text{app}} = \frac{h_1}{\mu_1} + \frac{h_2}{\mu_2} = \frac{6}{3/2} + \frac{6}{8/5} = 4 + \frac{15}{4} = \frac{31}{4} \text{ cm}$$

Question4

A convex mirror of radius of curvature 30cm forms an image that is half the size of the object. The object distance is :

[29-Jan-2024 Shift 1]

Options:

A.

-15 cm

B.

45 cm

C.

-45 cm

D.

15 cm

Answer: A

Solution:

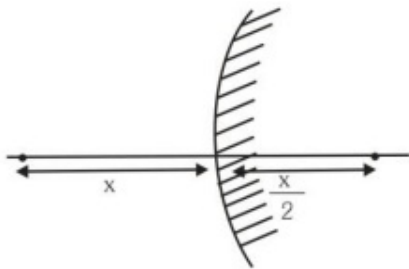

Given $R = 30 \text{ cm}$

$f = R/2 = +15 \text{ cm}$

Magnification (m) = $\pm \frac{1}{2}$

For convex mirror, virtual image is formed for real object.

Therefore, m is +ve

$$\frac{1}{2} = \frac{f}{f - u}$$

$$u = -15 \text{ cm}$$

Question5

A biconvex lens of refractive index 1.5 has a focal length of 20cm in air. Its focal length when immersed in a liquid of refractive index 1.6 will be:

[29-Jan-2024 Shift 1]

Options:

A.

-16 cm

B.

-160 cm

C.

+160 cm

D.

+16 cm

Answer: B

Solution:

$$\mu_1 = 1.5$$

$$\mu_m = 1.6$$

$$f_a = 20 \text{ cm}$$

$$\text{As } \frac{f_m}{f_a} = \frac{(\mu_1 - 1)\mu_m}{(\mu_1 - \mu_m)}$$

$$\frac{f_m}{20} = \frac{(1.5 - 1)1.6}{(1.5 - 1.6)}$$

$$f_m = -160 \text{ cm}$$

Question6

If the distance between object and its two times magnified virtual image produced by a curved mirror is 15cm, the focal length of the mirror must be :

[29-Jan-2024 Shift 2]

Options:

A.

15 cm

B.

-12 cm

C.

-10 cm

D.

10/3 cm

Answer: C

Solution:

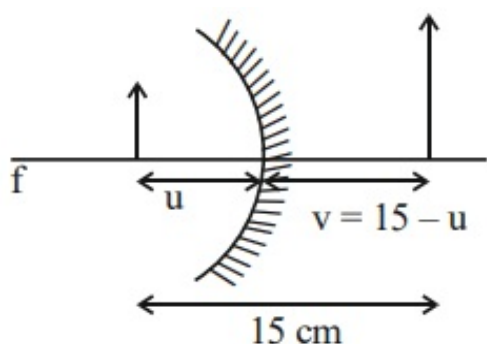

$$m = 2 = \frac{-v}{u}$$

$$2 = \frac{-(15-u)}{-u}$$

$$2u = 15 - u$$

$$3u = 15 \Rightarrow u = 5 \text{ cm}$$

$$v = 15 - u = 15 - 5 = 10 \text{ cm}$$

$$\frac{1}{f} = \frac{1}{v} + \frac{1}{u}$$

$$= \frac{1}{10} + \frac{1}{(-5)} = \frac{1-2}{10} = \frac{-1}{10}$$

$$f = -10 \text{ cm}$$

Question7

The distance between object and its two times magnified real image as produced by a convex lens is 45cm. The focal length of the lens used is ___ cm.

[30-Jan-2024 Shift 1]

Answer: 10

Solution:

$$\frac{v}{u} = -2$$

$$v = -2u \dots (i)$$

$$v - u = 45 \dots (ii)$$

$$\Rightarrow u = -15 \text{ cm}$$

$$v = 30 \text{ cm}$$

$$\frac{1}{f} = \frac{1}{v} - \frac{1}{u}$$

$$f = +10 \text{ cm}$$

Question 8

In an experiment to measure the focal length (f) of a convex lens, the magnitude of object distance (x) and the image distance (y) are measured with reference to the focal point of the lens. The $y - x$ plot is shown in figure.

The focal length of the lens is ____ cm.

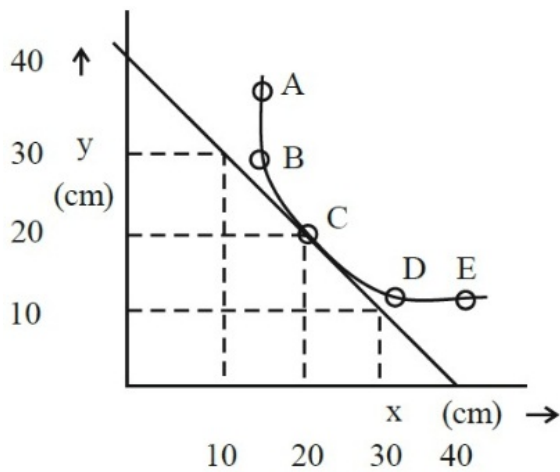

[30-Jan-2024 Shift 2]

Answer: 20

Solution:

$$\frac{1}{f+20} - \frac{1}{-(f+20)} = \frac{1}{f}$$

$$\frac{2}{f+20} = \frac{1}{f} \quad f = 20 \text{ cm}$$

$$\text{Or } x_1 x_2 = f^2 \text{ gives } f = 20 \text{ cm}$$

Question9

The refractive index of a prism with apex angle A is $\cot A/2$. The angle of minimum deviation is :

[31-Jan-2024 Shift 1]

Options:

A.

$$\delta_m = 180^\circ - A$$

B.

$$\delta_m = 180^\circ - 3A$$

C.

$$\delta_m = 180^\circ - 4A$$

D.

$$\delta_m = 180^\circ - 2A$$

Answer: D

Solution:

$$\mu = \frac{\sin\left(\frac{A + \delta_m}{2}\right)}{\sin\frac{A}{2}}$$

$$\frac{\cos\frac{A}{2}}{\sin\frac{A}{2}} = \frac{\sin\left(\frac{A + \delta_m}{2}\right)}{\sin\frac{A}{2}}$$

$$\sin\left(\frac{\pi}{2} - \frac{A}{2}\right) = \sin\left(\frac{A + \delta_m}{2}\right)$$

$$\frac{\pi}{2} - \frac{A}{2} = \frac{A}{2} + \frac{\delta_m}{2}$$

$$\delta_m = \pi - 2A$$

Question10

Light from a point source in air falls on a convex curved surface of radius 20cm and refractive index 1.5. If the source is located at 100cm from the convex surface, the image will be formed at _____ cm from the object.



[31-Jan-2024 Shift 2]

Solution:

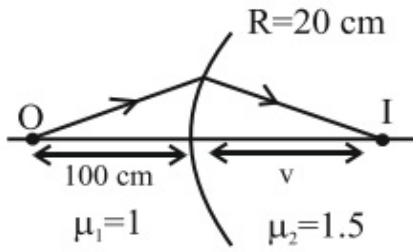

$$\frac{\mu_2}{v} - \frac{\mu_1}{u} = \frac{\mu_2 - \mu_1}{R}$$

$$\frac{1.5}{v} - \frac{1}{-100} = \frac{1.5 - 1}{20}$$

$$v = 100 \text{ cm}$$

Distance from object

$$= 100 + 100$$

$$= 200 \text{ cm}$$

Question 11

The distance between object and its 3 times magnified virtual image as produced by a convex lens is 20cm. The focal length of the lens used is _____ cm.

[1-Feb-2024 Shift 1]

Answer: 15

Solution:

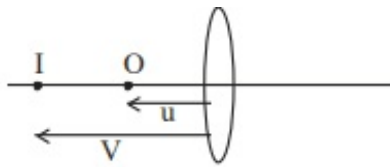

$$v = 3u$$

$$v - u = 20 \text{ cm}$$

$$2u = 20 \text{ cm}$$

$$u = 10 \text{ cm}$$

$$\frac{1}{(-30)} - \frac{1}{(-10)} = \frac{1}{f}$$

$$f = 15 \text{ cm}$$

Question12

As shown in the figure, a combination of a thin plano concave lens and a thin plano convex lens is used to image an object placed at infinity. The radius of curvature of both the lenses is 30 cm and refraction index of the material for both the lenses is 1.75. Both the lenses are placed at distance of 40 cm from each other. Due to the combination, the image of the object is formed at distance $x = \underline{\hspace{1cm}}$ cm, from concave lens.

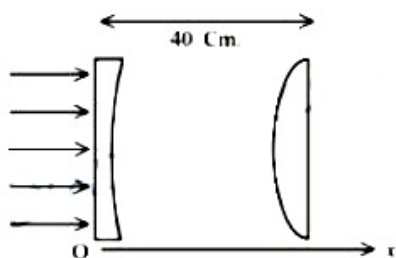

----- [2023 Shift 1]

Answer: 120

Solution:

$$\frac{1}{f_1} = (1.75 - 1) \left(-\frac{1}{30} \right)$$
$$\Rightarrow f_1 = -40 \text{ cm}$$

$$\frac{1}{f_2} = (1.75 - 1) \left(\frac{1}{30} \right) \Rightarrow f_2 = 40 \text{ cm}$$

Image from L_1 will be virtual and on the left of L_1 at focal length 40 cm. So the object for L_2 will be 80 cm from L_2 which is $2f$. Final image is formed at 80 cm from L_2 on the right.

So $x = 120$

Question13

When a beam of white light is allowed to pass through convex lens parallel to principal axis, the different colours of light converge at different point on the principle axis after refraction. This is called:
[24-Jan-2023 Shift 2]

Options:

- A. Scattering
- B. Chromatic aberration
- C. Spherical aberration
- D. Polarisation

Answer: B

Solution:

Based on fact

Question14

A convex lens of refractive index 1.5 and focal length 18 cm in air is immersed in water. The change in focal length of the lens will be cm.

(. Given refractive index of water = $\frac{4}{3}$)

[24-Jan-2023 Shift 2]

Answer: 54

$$\frac{1}{f_{\text{H}_2\text{O}}} = \left(\frac{\mu_g}{\mu_{\text{H}_2\text{O}}} - 1 \right) \left(\frac{2}{R} \right)$$
$$= \frac{1}{8} \left(\frac{2}{R} \right)$$

$$\text{So, } f_{\text{H}_2\text{O}} = 4f_{\text{air}} = 72 \text{ cm}$$

$$\text{So change in focal length} = 72 - 18 = 54 \text{ cm}$$

Question15

A ray of light is incident from air on a glass plate having thickness $\sqrt{3}$ cm and refractive index $\sqrt{2}$. The angle of incidence of a ray is equal to the critical angle for glass-air interface. The lateral displacement of the ray when it passes through the plate is $\times 10^{-2}$ cm. (given $\sin 15^\circ = 0.26$)

[25-Jan-2023 Shift 1]

Solution:

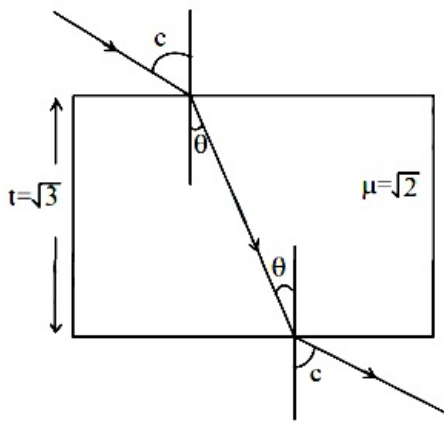

$$\sin c = \frac{1}{\sqrt{2}}$$

$$c = 45^\circ$$

$$\sin c = \mu \sin \theta$$

$$\frac{1}{\sqrt{2}} = \sqrt{2} \sin \theta$$

$$\theta = 30^\circ$$

Lateral displacement:

$$x = t \sin(i - r) \sec r$$

$$x = \sqrt{3} \sin(45^\circ - 30^\circ) \sec 30^\circ$$

$$x = \sqrt{3}(0.26) \left(\frac{2}{\sqrt{3}} \right)$$

$$x = 0.52 \text{ cm}$$

$$x = 52 \times 10^{-2} \text{ cm}$$

Question 16

The light rays from an object have been reflected towards an observer from a standard flat mirror, the image observed by the observer are :-

- A. Real
- B. Erect
- C. Smaller in size than object
- D. Laterally inverted

Choose the most appropriate answer from the options given below :
[25-Jan-2023 Shift 2]

Options:

- A. B and D only
- B. B and C only
- C. A and D only
- D. A, C and D only

Answer: A

Solution:

Solution:

Plane mirror forms erect, same sized, laterally inverted and virtual image of real object.



Question17

An object is placed on the principal axis of convex lens of focal length 10 cm as shown. A plane mirror is placed on the other side of lens at a distance of 20 cm. The image produced by the plane mirror is 5 cm inside the mirror. The distance of the object from the lens is ____ cm.

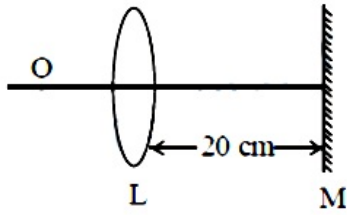

[25-Jan-2023 Shift 2]

Solution:

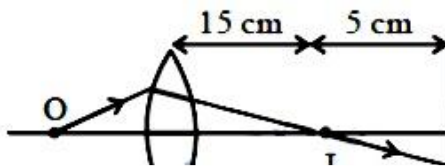

$$f = 10 \text{ cm}$$

$$\frac{1}{v} - \frac{1}{u} = \frac{1}{f}$$

$$\frac{1}{15} - \frac{1}{-u} = \frac{1}{10}$$

$$\Rightarrow \frac{1}{u} = \frac{1}{10} - \frac{1}{15}$$

On solving we get value of u as 30 cm.

Question18

A scientist is observing a bacteria through a compound microscope. For better analysis and to improve its resolving power he should. (Select the best option)

[29-Jan-2023 Shift 2]

Options:

- A. Increase the wave length of the light
- B. Increase the refractive index of the medium between the object and objective lens
- C. Decrease the focal length of the eye piece
- D. Decrease the diameter of the objective lens

Answer: B

Solution:

Solution:

$$P = \frac{2\mu \sin \theta}{1.22\lambda}$$

Question19

A person has been using spectacles of power-1.0 diopter for distant vision and a separate reading glass of power 2.0 diopters. What is the least distance of distinct vision for this person:

[30-Jan-2023 Shift 1]

Options:

- A. 10 cm
- B. 40 cm
- C. 30 cm
- D. 50 cm

Answer: D

Solution:

$$\frac{1}{v} - \frac{1}{u} = \frac{1}{f}$$

$$P = 2D = 2\text{m}^{-1}$$

$$\Rightarrow \frac{1}{f} = \frac{2}{100}\text{cm}^{-1}$$

$$\frac{1}{V} - \left(-\frac{1}{25}\right) = \frac{2}{100}$$

$$\Rightarrow \frac{1}{V} = \frac{1}{50} - \frac{1}{25}$$

$$\Rightarrow V = -50\text{ cm}$$

Question20

In an experiment for estimating the value of focal length of converging mirror, image of an object placed at 40 cm from the pole of the mirror is formed at distance 120 cm from the pole of the mirror. These distances are measured with a modified scale in which there are 20 small divisions in 1 cm. The value of error in measurement of focal length of the mirror is 1 / K cm. The value of K is _____.

[30-Jan-2023 Shift 1]

Answer: 3

Solution:

$$\frac{1}{v} - \frac{1}{u} = \frac{1}{f}$$
$$\frac{-1}{120} - \frac{1}{40} = \frac{1}{f}, \quad f = -30 \text{ cm}$$

Now,

$$\frac{-1}{v^2} dv - \frac{1}{u^2} du = -\frac{1}{f^2} df$$

$$\text{Also } dv = du = \frac{1}{20} \text{ cm}$$

$$\therefore \frac{\frac{1}{20}}{(120)^2} + \frac{\frac{1}{20}}{(40)^2} = \frac{df}{(30)^2}$$

On solving

$$df = \frac{1}{32} \text{ cm}$$

$$\therefore k = 32$$

Question21

A thin prism P_1 with an angle 6° and made of glass of refractive index 1.54 is combined with another prism P_2 made from glass of refractive index 1.72 to produce dispersion without average deviation. The angle of prism P_2 is :

[30-Jan-2023 Shift 2]

Options:

- A. 6°
- B. 1.3°
- C. 7.8°
- D. 4.5°

Answer: D

Solution:

Solution:

$$\delta_1 = \delta_2 \text{ [for no average deviation]}$$

$$\Rightarrow 6^\circ(1.54 - 1) = A(1.72 - 1)$$

$$\Rightarrow A = \frac{6^\circ \times 0.54}{0.72}$$

$$= \frac{18^\circ}{4} = 4.5^\circ$$

Question22

In a medium the speed of light wave decreases to 0.2 times to its speed in free space The ratio of relative permittivity to the refractive index of the medium is $x : 1$. The value of x is _____.

(Given speed of light in free space = $3 \times 10^8 \text{ m s}^{-1}$ and for the given medium $\mu_r = 1$)

[31-Jan-2023 Shift 1]

Solution:

$$V = \frac{C}{\mu} \Rightarrow \mu = \frac{C}{V} = \frac{C}{0.2C}$$

$$\mu = 5$$

$$\Rightarrow E_r = \frac{\mu}{\mu_r}$$

$$\therefore \frac{E_r}{\mu} = \frac{\mu}{\mu_r} = 5$$

Question23

A microscope is focused on an object at the bottom of a bucket. If liquid with refractive index - is poured inside the bucket, then microscope have to be raised by 30 cm to focus the object again. The height of the liquid in the bucket is :

[31-Jan-2023 Shift 2]

Options:

A. 75 cm

B. 50 cm

C. 18 cm

D. 12 cm

Answer: A

Solution:

Solution:

$$\text{Shift} = \left(d - \frac{d}{\mu} \right) = 30 \text{ cm}$$



$$\Rightarrow d \left[1 - \frac{1}{\frac{5}{3}} \right] = 30$$

$$\Rightarrow d = \frac{30 \times 5}{2} = 75 \text{ cm}$$

Question24

A thin cylindrical rod of length 10 cm is placed horizontally on the principle axis of a concave mirror of focal length 20 cm. The rod is placed in a such a way that mid point of the rod is at 40 cm from the pole of mirror. The length of the image formed by the mirror will be $\frac{x}{3}$ cm. The value of x is _____.

[1-Feb-2023 Shift 1]

Solution:



$$U_A = -45 \text{ cm}, f = -20 \text{ cm}$$

$$V_A = \frac{-45 \times (-20)}{-45 - (-20)} = \frac{-900}{-25} = -36 \text{ cm}$$

$$\text{And } U_B = -35 \text{ cm}$$

$$\therefore V_B = \frac{-35 \times (-20)}{-35 - (-20)} = \frac{700}{-15}$$

$$\therefore V_A - V_B = \text{length of image}$$

$$= \left(-36 + \frac{140}{3} \right) \text{ cm}$$

$$= \frac{-108 + 140}{3} \text{ cm}$$

$$= \frac{32}{3} \text{ cm}$$

$$\therefore x = 32$$

Question25

Two objects A and B are placed at 15 cm and 25 cm from the pole in front of a concave mirror having radius of curvature 40 cm. The distance between images formed by the mirror is:

[1-Feb-2023 Shift 2]

Options:

- A. 40 cm
- B. 60 cm
- C. 160 cm
- D. 100 cm

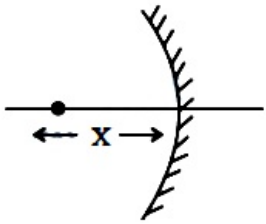
Answer: C**Solution:****Solution:**

by mirror formula

$$\frac{1}{v} + \frac{1}{u} = \frac{1}{f}$$

$$\frac{1}{v_1} + \frac{1}{-15} = \frac{1}{(-20)}$$

$$\frac{1}{v_1} = -\frac{1}{20} + \frac{1}{15}$$

$$= \frac{-3 + 4}{60}$$

$$v_1 = 60 \text{ cm}$$

$$\frac{1}{v_2} + \frac{1}{(-25)} = \frac{1}{(-20)}$$

$$\frac{1}{v_2} = \frac{-1}{20} + \frac{1}{25}$$

$$= \frac{-5 + 4}{100} = \frac{-1}{100}$$

$$v_2 = -100 \text{ cm}$$

$$d = 60 + 100 = 160 \text{ cm}$$

Question26

A monochromatic light wave with wavelength λ_1 and frequency ν_1 in air enters another medium. If the angle of incidence and angle of refraction at the interface are 45° and 30° respectively, then the wavelength λ_2 and frequency ν_2 of the refracted wave are :

[6-Apr-2023 shift 1]**Options:**

A. $\lambda_2 = \frac{1}{\sqrt{2}}\lambda_1, \nu_2 = \nu_1$

B. $\lambda_2 = \lambda_1, \nu_2 = \frac{1}{\sqrt{2}}\nu_1$

C. $\lambda_2 = \lambda_1, \nu_2 = \sqrt{2}\nu_1$

$$D. \lambda_2 = \sqrt{2}\lambda_1, v_2 = v_1$$

Answer: A

Solution:

Solution:

$$1 \times \sin 45 = \mu \sin 30$$

$$\Rightarrow \frac{1}{\sqrt{2}} = \mu \times \frac{1}{2}$$

$$\Rightarrow \mu = \sqrt{2} \text{----- (i)}$$

$$\text{Now, } \frac{\mu_1}{\mu_2} = \frac{V_2}{V_1} = \frac{\lambda_2}{\lambda_1} \text{----- (ii)}$$

Using eq (i) and (ii),

$$\lambda_2 = \frac{1}{\sqrt{2}}\lambda_1$$

$$\text{And } V_2 = \frac{1}{\sqrt{2}}V_1$$

Now, for relation between frequencies,

$$\text{Frequency, } v = \frac{v}{\lambda}$$

$$\text{Or } \frac{v_1}{v_2} = \frac{v_1}{v_2} \times \frac{\lambda_2}{\lambda_1} = 1$$

$$v_1 = v_2$$

Question27

A pole is vertically submerged in swimming pool, such that it gives a length of shadow 2.15m within water when sunlight is incident at an angle of 30° with the surface of water. If swimming pool is filled to a height of 1.5m, then the height of the pole above the water surface in centimeters is ($n_w = 4 / 3$) _____.

[6-Apr-2023 shift 1]

Answer: 50

Solution:

Solution:

$$\sin 60 = \frac{4}{3}\sin r$$

$$\Rightarrow \sin r = \frac{3}{4} \times \frac{\sqrt{3}}{2} = \frac{3\sqrt{3}}{8} \text{----- (i)}$$

$$\cos r = \sqrt{1 - \frac{27}{64}} = \frac{\sqrt{37}}{8} = 0.75$$

$$\Rightarrow \tan r = \sqrt{\frac{27}{37}}$$

$$\Rightarrow \frac{x}{1.5} = 0.85$$

$$\Rightarrow x = 0.85 \times 1.5 = 1.275\text{m}$$

$$\tan 30 = \frac{y}{2.15 - 1.275} = \frac{y}{0.875}$$

$$y = \frac{0.875}{1.732} = 0.50$$

So length of pole above water surface = 0.50m = 50 cm

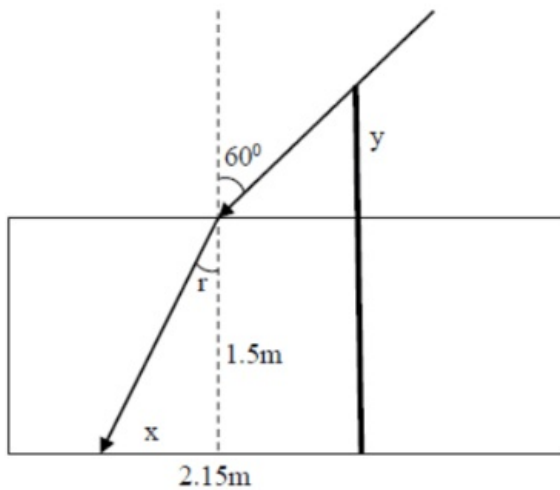

Question28

A 2 meter long scale with least count of 0.2 cm is used to measure the locations of objects on an optical bench. While measuring the focal length of a convex lens, the object pin and the convex lens are placed at 80 cm mark and 1m mark., respectively. The image of the object pin on the other side of lens coincides with image pin that is kept at 180 cm mark. The % error in the estimation of focal length is :

[6-Apr-2023 shift 2]

Options:

- A. 0.51
- B. 1.02
- C. 0.85
- D. 1.70

Answer: D

Solution:

Solution:

Based on the data provided

$$U = 100 - 80 = 20 \text{ cm}$$

$$V = 180 - 100 = 80 \text{ cm}$$

$$\text{Using } \frac{1}{f} = \frac{1}{v} + \frac{1}{u} \text{ or } f = \frac{uv}{u+v} = \frac{20 \times 80}{20+80} \text{ or } f = 16 \text{ cm}$$

For error analysis,

$$\frac{1}{f} = \frac{1}{v} + \frac{1}{u}$$

Differentiating

$$-\frac{Df}{f^2} = -\frac{Dv}{v^2} - \frac{\Delta u}{u^2}$$

To calculate Δu & Δv

$$U = (100 \pm 2) - (80 \pm 0.2) = (20 \pm 0.4) \text{ cm}$$

Therefore $\Delta u = 0.4 \text{ cm}$,

Similarly $\Delta v = 0.4 \text{ cm}$.

Now $\frac{\Delta f}{f} = f \left[\frac{\Delta v}{v^2} + \frac{\Delta u}{u^2} \right]$

$\frac{\Delta f}{f} = 16 \left[\frac{0.4}{(80)^2} + \frac{0.4}{(20)^2} \right]$

(Note: every data is in cm)

$\frac{\Delta f}{f} = \frac{16 \times 0.4}{(20)^2} \left[\frac{1}{4^2} + 1 \right]$

$= \frac{16 \times 0.4}{20^2} \times \frac{17}{16} = \frac{17 \times 0.4}{400}$

% Error : $\frac{\Delta f}{f} \times 100 = \frac{17 \times 0.4}{400} \times 1000$
 $= 1.7$

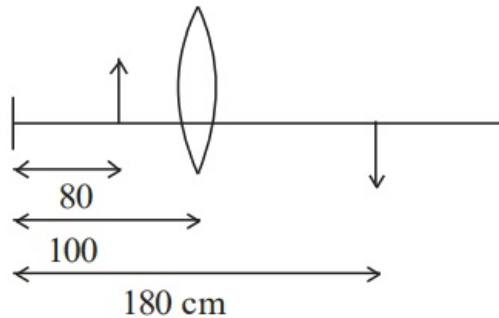

Question29

Given below are two statements : one is labelled as assertion A and the other is labelled as Reason R

Assertion A : The phase difference of two light wave change if they travel through different media having same thickness, but different indices of refraction

Reason R : The wavelengths of waves are different in different media.

In the light of the above statements, choose the most appropriate answer from the options given below

[6-Apr-2023 shift 2]

Options:

- A. Both A and R are correct and R is the correct explanation of A
- B. A is not correct but R is correct
- C. A is correct but R is not correct
- D. Both A and R are correct but R is NOT the correct explanation of A

Answer: A

Solution:

Solution:

Both the statements are true

As we know speed of light in a medium

$v = \frac{c}{\mu}$ or $f\lambda = \frac{c}{\mu}$

therefore $\lambda \propto \frac{1}{\mu}$

when light will travel through two different mediums their phase difference will change $\Delta Q = \frac{2\pi}{\lambda} \Delta x$

and R is correction explanation

Question30

In a reflecting telescope, a secondary mirror is used to:
[8-Apr-2023 shift 1]

Options:

- A. Make chromatic aberration zero
- B. Reduce the problem of mechanical support
- C. Move the eyepiece outside the telescopic tube
- D. Remove spherical aberration

Answer: C

Solution:

Solution:

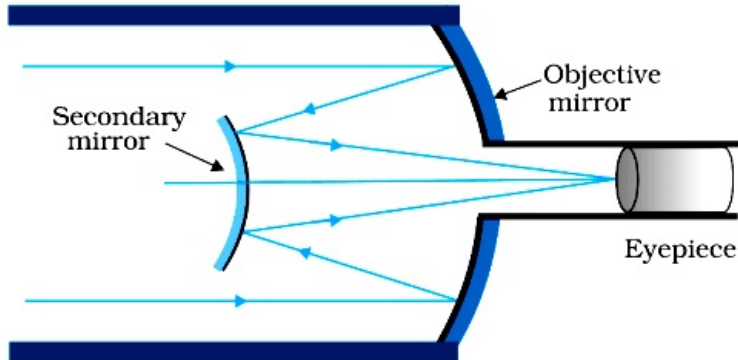

To move the eye piece outside the telescopic tube

Question31

Two vertical parallel mirrors A and B are separated by 10 cm. A point object O is placed at a distance of 2 cm from mirror A. The distance of the second nearest image behind mirror A from the mirror A is _____ cm.

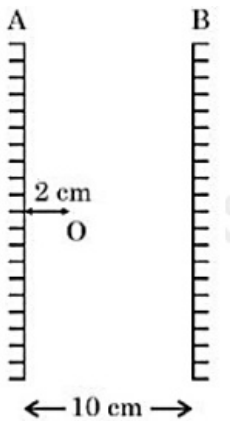

[8-Apr-2023 shift 1]



Answer: 18

Solution:

Solution:

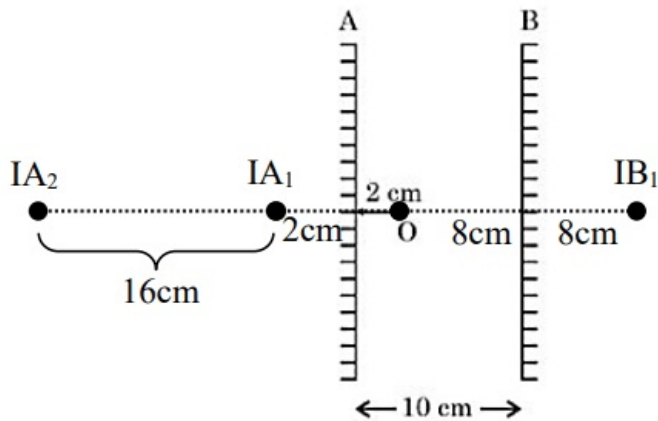

$$d = 2 + 16$$
$$d = 18 \text{ cm}$$

Question32

Two transparent media having refractive indices 1.0 and 1.5 are separated by a spherical refracting surface of radius of curvature 30 cm. The centre of curvature of surface is towards denser medium and a point object is placed on the principle axis in rarer medium at a distance of 15 cm from the pole of the surface. The distance of image from the pole of the surface is _____ cm.

[8-Apr-2023 shift 2]

SOLUTION:

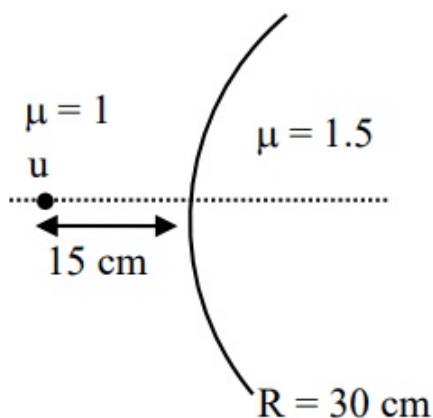

$$\frac{1.5}{v} - \frac{1}{(-15)} = \frac{1.5 - 1}{30}$$
$$\Rightarrow \frac{1.5}{v} - \frac{1}{60} - \frac{1}{15} = \frac{1 - 4}{60}$$

$$V = -30 \text{ cm}$$
$$= 30 \text{ cm}$$

Question33

An object is placed at a distance of 12 cm in front of a plane mirror. The virtual and erect image is formed by the mirror. Now the mirror is moved by 4 cm towards the stationary object. The distance by which the position of image would be shifted, will be [10-Apr-2023 shift 1]

Options:

- A. 4 cm towards mirror
- B. 8 cm away from mirror
- C. 2 cm towards mirror
- D. 8 cm towards mirror

Answer: D

Solution:

Solution:

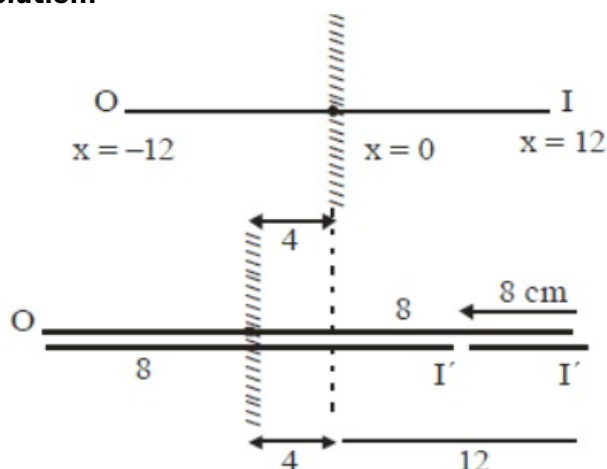

8 cm towards mirror
Image will be shifted 8 cm towards mirror.

Question34

A point object, 'O' is placed in front of two thin symmetrical coaxial convex lenses L_1 and L_2 with focal length 24 cm and 9 cm respectively. The distance between two lenses is 10 cm and the object is placed 6 cm away from lens L_1 as shown in the figure. The distance between the object and the image formed by the system of two lenses is _____ cm.

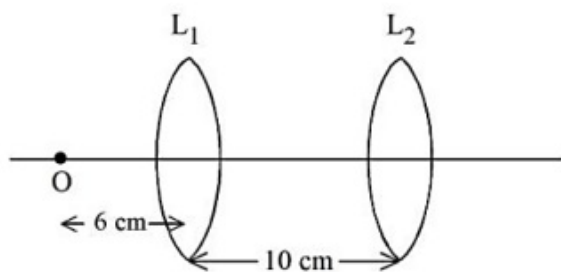

[10-Apr-2023 shift 2]

Solution:

Solution:

Due to lens L_1

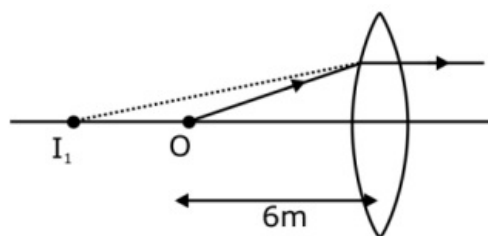

$$u = -6\text{m}$$

$$f = +24\text{m}$$

$$\frac{1}{v} - \frac{1}{u} = \frac{1}{f}$$

$$\frac{1}{v} = \frac{1}{24} - \frac{1}{6} = \frac{1-4}{24} \Rightarrow v = -8\text{m}$$

Due to lens L_2

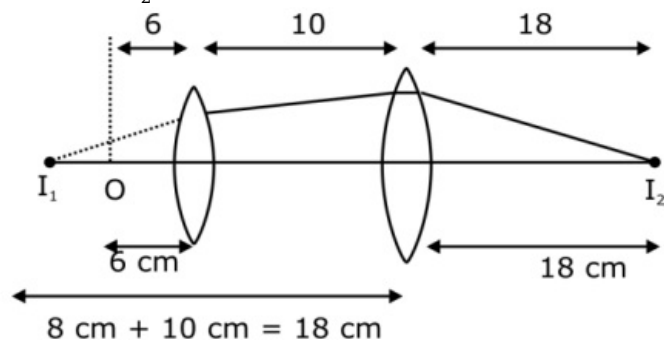

$$U = -18\text{m}$$

$$F = +9\text{m}$$

$$\frac{1}{v} - \frac{1}{u} = \frac{1}{f}$$

$$\frac{1}{v} - \frac{1}{9} = \frac{1}{18}$$

$$V = \frac{1}{v} = \frac{2-1}{18}$$

$$V = 18\text{m}$$

Question35

The critical angle for a denser-rarer interface is 45° . The speed of light in rarer medium is $3 \times 10^8 \text{m/s}$. The speed of light in the denser medium is :

[11-Apr-2023 shift 1]



Options:

A. $2.12 \times 10^8 \text{ m / s}$

B. $5 \times 10^7 \text{ m / s}$

C. $3.12 \times 10^7 \text{ m / s}$

D. $\sqrt{2} \times 10^8 \text{ m / s}$

Answer: A**Solution:****Solution:**

$$\sin i_c = \frac{\mu_r}{\mu_d} \Rightarrow \sin 45^\circ = \frac{\mu_r}{\mu_d}$$

$$\Rightarrow \frac{\mu_r}{\mu_d} = \frac{1}{\sqrt{2}} \dots (1)$$

We know

$$V \propto \frac{1}{\mu} \Rightarrow \frac{V_d}{V_r} = \frac{\mu_r}{\mu_d}$$

$$= \frac{V_d}{3 \times 10^8} = \frac{1}{\sqrt{2}}$$

$$V_d = \frac{3}{\sqrt{2}} \times 10^8 = 3 \times 0.7 \times 10^8$$

$$V_d = 2.12 \times 10^8 \text{ m / sec}$$

Ans. Option (1)

Question36

The radius of curvature of each surface of a convex lens having refractive index 1.8 is 20 cm. The lens is now immersed in a liquid of refractive index 1.5. The ratio of power of lens in air to its power in the liquid will be $x : 1$. The value of x is _____.

[11-Apr-2023 shift 1]**SOLUTION:**

$$\frac{1}{f} = \left(\frac{\mu_l}{\mu_m} - 1 \right) \left(\frac{1}{R} - \frac{1}{-R} \right)$$

$$\left[\frac{1.8}{1} - 1 \right]$$

$$P_1 = \frac{2}{R}(0.8) = \frac{1.6}{R} \dots (1)$$

Now,

$$P_2 = \frac{2}{R} \left[\frac{1.8}{1.5} - 1 \right]$$



$$P_2 = \frac{2}{R} \left[\frac{0.3}{1.5} \right] = \frac{2}{R} \times \frac{1}{5} = \frac{2}{5R}$$

$$\frac{P_{\text{air}}}{P_{\text{liquid}}} = \frac{P_1}{P_2} = \frac{\left(\frac{1.6}{R} \right)}{\left(\frac{0.4}{R} \right)} = \frac{4}{1}$$

Ans. → 4

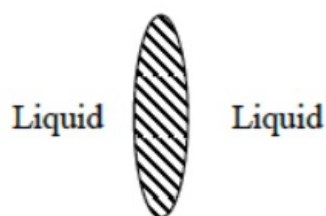
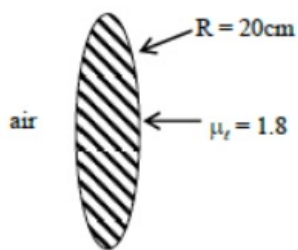

Question37

When one light ray is reflected from a plane mirror with 30° angle of reflection, the angle of deviation of the ray after reflection is:
[11-Apr-2023 shift 2]

Options:

- A. 140°
- B. 130°
- C. 120°
- D. 110°

Answer: C

Solution:

Solution:

$$\delta = \Pi - 2i = \Pi - 2 \times 30$$

$$= 180 - 60 = 120^\circ$$

Question38

As shown in the figure, a plane mirror is fixed at a height of 50 cm from the bottom of tank containing water ($\mu = \frac{4}{3}$). The height of water in the tank is 8 cm. A small bulb is placed at the bottom of the water tank. The distance of image of the bulb formed by mirror from the bottom of the tank is _____ cm.

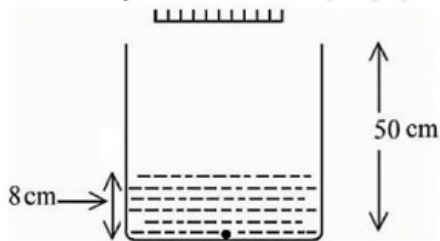

[11-Apr-2023 shift 2]

Answer: 98

Solution:

Solution:

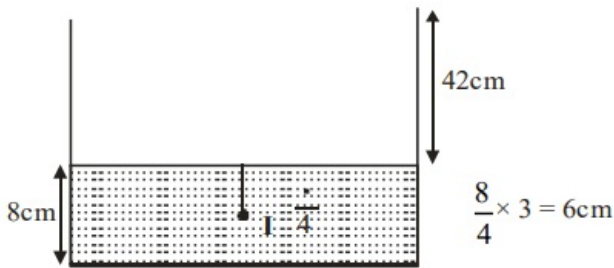

$$\text{Apparent depth of } O = \frac{d}{\mu} = 6$$

$$\text{Distance between } O \text{ and } I_2 = 48 + 50 = 98 \text{ cm}$$

Question39

An ice cube has a bubble inside. When viewed from one side the apparent distance of the bubble is 12 cm. When viewed from the opposite side, the apparent distance of the bubble is observed as 4 cm. If the side of the ice cube is 24 cm, the refractive index of the ice cube is [12-Apr-2023 shift 1]

Options:

A. $\frac{4}{3}$

B. $\frac{3}{2}$

C. $\frac{2}{3}$

D. $\frac{6}{5}$

Answer: B

Solution:

Solution:

Question says small bubble is trapped inside a cube of length 24 cm. If apparent distance of bubble is 12 cm and 4 cm from one and other side and find $x = ?$

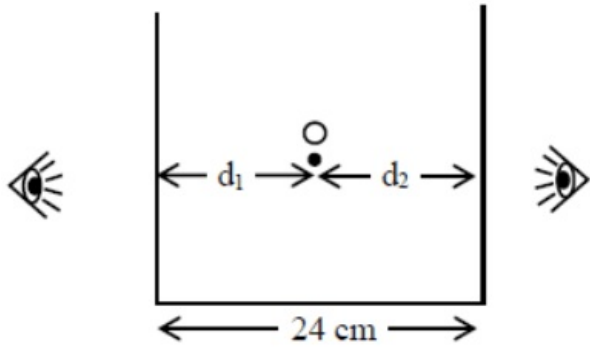

Using $\frac{\text{Apparent depth}}{\text{Real depth}} = \frac{\mu_2}{\mu_1}$

$\mu_2 = 1$ μ_1 is glass

$\mu_1 = \mu$ μ_2 is air

$\frac{12}{d_1} = \frac{1}{\mu}$

$\frac{12\mu}{4} = d_1 = \frac{1}{\mu} \Rightarrow (1)$

$d_1 + d_2 = 24 \text{ m} \Rightarrow 12\mu + 4\mu = 24 \Rightarrow d_2$

Question40

Two convex lenses of focal length 20 cm each are placed coaxially with a separation of 60 cm between them. The image of the distant object formed by the combination is at _____ cm from the first lens.

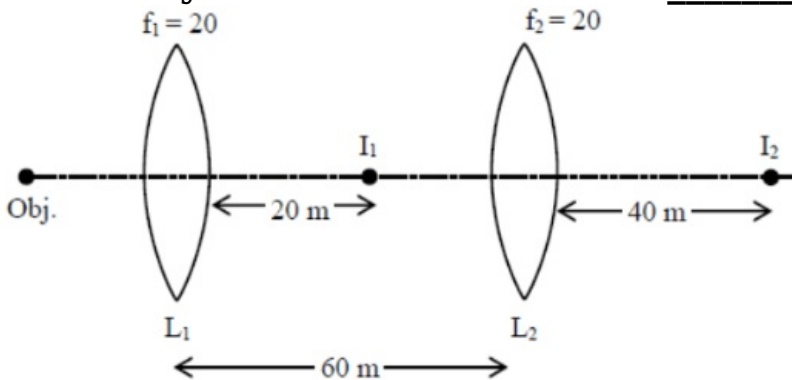

[12-Apr-2023 shift 1]

Answer: 100

Solution:

Solution:

For 1st lens

$$\frac{1}{V_1} - \frac{1}{\infty} = \frac{1}{20}$$

$$V_1 = 20 \text{ cm}$$

For 2nd lens

$$\frac{1}{V_2} - \frac{1}{-40} = \frac{1}{20}$$

$$V_2 = 40 \text{ cm}$$

$$\text{So dist} = 40 + 60 = 100 \text{ cm}$$

Question41

A vessel of depth ' d ' is half filled with oil of refractive index n_1 and the other half is filled with water of refractive index n_2 . The apparent depth of this vessel when viewed from above will be -
[13-Apr-2023 shift 1]

Options:

A. $\frac{d(n_1 + n_2)}{2n_1n_2}$

B. $\frac{dn_1n_2}{(n_1 + n_2)}$

C. $\frac{dn_1n_2}{2(n_1 + n_2)}$

D. $\frac{2d(n_1 + n_2)}{n_1n_2}$

Answer: A

Solution:

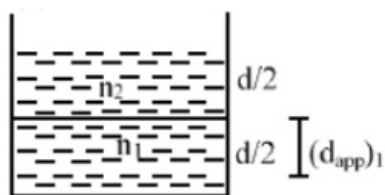

$$(d_{spp})_1 = \frac{d}{2 \left(\frac{n_1}{n_2} \right)} = \frac{n_2 d}{2n_1}$$

$$(d_{app})_2 = \frac{(d_{spp})_1 + \frac{d}{2}}{n_2}$$

$$= \frac{\left(\frac{n_2}{n_1} + 1\right) \frac{d}{2}}{n_2}$$

$$(d_{\text{spp}})_2 = \frac{(n_1 + n_2)d}{2n_1n_2}$$

Question42

A fish rising vertically upward with a uniform velocity of 8ms^{-1} , observes that a bird is diving vertically downward towards the fish with the velocity of 12ms^{-1} . If the refractive index of water is $\frac{4}{3}$, then the actual velocity of the diving bird to pick the fish, will be _____ ms^{-1} .
[13-Apr-2023 shift 1]

Answer: 3

Solution:

Solution:

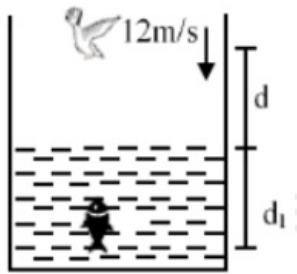

$$d_{\text{app}} = d_1 + \mu d$$

$$v_{\text{app}} = v_1 + \mu v$$

$$12 = 8 + \frac{4}{3}v$$

$$4 = \frac{4}{3}v$$

$$v = 3\text{m / s}$$

Question43

A bi convex lens of focal length 10 cm is cut in two identical parts along a plane perpendicular to the principal axis. The power of each lens after cut is _____ D.
[13-Apr-2023 shift 2]

SOLUTION:

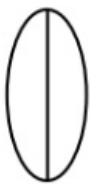

$$P_1 + P_1 = P = \frac{1}{f}$$

$$2P_1 = \frac{1}{0.1}$$

$$P_1 = 5D$$

Question44

The refractive index of a transparent liquid filled in an equilateral hollow prism is $\sqrt{2}$. The angle of minimum deviation for the liquid will be _____.

[15-Apr-2023 shift 1]

SOLUTION:

For minimum deviation

$$r = \frac{A}{2} = \frac{60}{2} = 30^\circ$$

$$1 \sin i = \sqrt{2} \sin r$$

$$\sin i = \sqrt{2} \times \sin 30^\circ$$

$$\sin i = \frac{1}{\sqrt{2}}$$

$$i = 45^\circ$$

$$\delta_{\min} = 2i - A = 90 - 60 = 30^\circ$$

$$\delta_{\min} = 30^\circ$$

Question45

Two identical thin biconvex lens of focal length 15 cm and refractive index 1.5 are in contact with each other. The space between the lenses is filled with a liquid of refractive index 1.25. The focal length of the combination is ____ cm.

[24-Jun-2022-Shift-1]

Answer: 10

Solution:

$$\frac{1}{f_{1_1}} = (\mu_m - 1) \left(\frac{1}{R_1} - \frac{1}{R_2} \right)$$

here $|R_1| = |R_2| = R$

$$\Rightarrow \frac{1}{f_{1_1}} = (1.5 - 1) \left(\frac{2}{R} \right) = \frac{1}{15}$$

$$\Rightarrow \frac{1}{R} = \frac{1}{15} \text{ or } R = 15 \text{ cm}$$

for the concave lens made up of liquid

$$\frac{1}{f_{1_2}} = (1.25 - 1) \left(-\frac{2}{R} \right) = -\frac{1}{30} \text{ cm}$$

now for equivalent lens

$$\frac{1}{f_e} = \frac{2}{f_{1_1}} + \frac{1}{f_{1_2}}$$

$$= \frac{2}{15} - \frac{1}{30} = \frac{3}{30} = \frac{1}{10}$$

or $f_e = 10 \text{ cm}$

Question46

A ray of light is incident at an angle of incidence 60° on the glass slab of refractive index $\sqrt{3}$. After refraction, the light ray emerges out from other parallel faces and lateral shift between incident ray and emergent ray is $4\sqrt{3} \text{ cm}$. The thickness of the glass slab is _____ cm.

[24-Jun-2022-Shift-2]

$$1 \times \sin 60^\circ = \sqrt{3} \times \sin r$$

$$\Rightarrow r = 30^\circ$$

$$\therefore l_1 = 4\sqrt{3} \times 2$$

$$= 8\sqrt{3} \text{ cm}$$

$$\therefore \text{Thickness, } t = l_1 \cos 30^\circ$$

$$= 8\sqrt{3} \times \frac{\sqrt{3}}{2}$$

$$= 4 \times 3$$

$$= 12 \text{ cm}$$

Question47

A light wave travelling linearly in a medium of dielectric constant 4, incidents on the horizontal interface separating medium with air. The angle of incidence for which the total intensity of incident wave will be reflected back into the same medium will be :

(Given : relative permeability of medium $\mu_r = 1$)

[25-Jun-2022-Shift-1]

Options:

- A. 10°
- B. 20°
- C. 30°
- D. 60°

Answer: D

Solution:

Solution:

$$n = \sqrt{K\mu} = 2 \text{ (} n \Rightarrow \text{ refractive index)}$$

So for TIR

$$\theta > \sin^{-1} \left(\frac{1}{n} \right)$$

$$\theta > 30$$

Only option is 60°

Question48

The difference of speed of light in the two media A and B ($v_A - v_B$) is $2.6 \times 10^7 \text{ m/s}$. If the refractive index of medium B is 1.47, then the ratio of refractive index of medium B to medium A is : (Given : speed of light in vacuum . $c = 3 \times 10^8 \text{ ms}^{-1}$)

[25-Jun-2022-Shift-1]

Options:

- A. 1.303



B. 1.318

C. 1.13

D. 0.12

Answer: C

Solution:

Solution:

Speed of light in a medium = $\frac{c}{n}$

⇒ According to given information,

$$\frac{c}{n_A} - \frac{c}{n_B} = 2.6 \times 10^7$$

$$\Rightarrow \frac{n_B}{n_A} - 1 = \frac{2.6 \times 10^7}{3 \times 10^8} \times n_B$$

$$\Rightarrow \frac{n_B}{n_A} \approx 1.13$$

Question49

A light whose electric field vectors are completely removed by using a good polaroid, allowed to incident on the surface of the prism at Brewster's angle. Choose the most suitable option for the phenomenon related to the prism.

[25-Jun-2022-Shift-2]

Options:

A. Reflected and refracted rays will be perpendicular to each other.

B. Wave will propagate along the surface of prism.

C. No refraction, and there will be total reflection of light.

D. No refraction, and there will be total transmission of light.

Answer: D

Solution:

Solution:

When electric field vector is completely removed and incident on Brewster's angle then only refraction takes place.

Question50

A light ray is incident, at an incident angle θ_1 , on the system of two plane mirrors M_1 and M_2 having an inclination angle 75° between them (as shown in figure). After reflecting from mirror M_1 it gets reflected



back by the mirror M_2 with an angle of reflection 30° . The total deviation of the ray will be ____ degree.

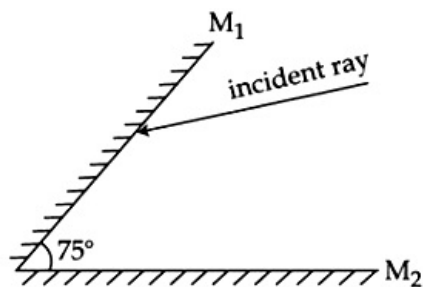

[26-Jun-2022-Shift-1]

Solution:

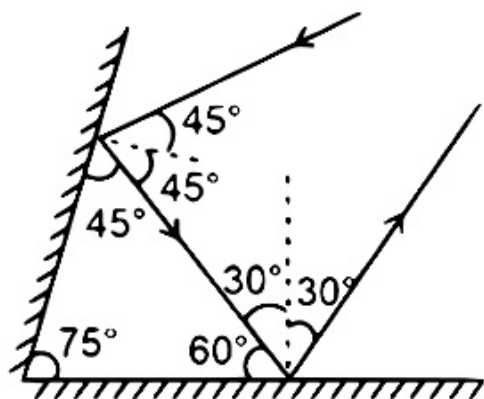

On first reflection angle of deviation is 90° and on second reflection angle of deviation is 120°
 So total deviation is $\delta = 90^\circ + 120^\circ = 210^\circ$

Question51

A small bulb is placed at the bottom of a tank containing water to a depth of $\sqrt{7}$ m. The refractive index of water is $\frac{4}{3}$. The area of the surface of water through which light from the bulb can emerge out is $x\pi\text{m}^2$. The value of x is ____

[26-Jun-2022-Shift-2]

Answer: 9



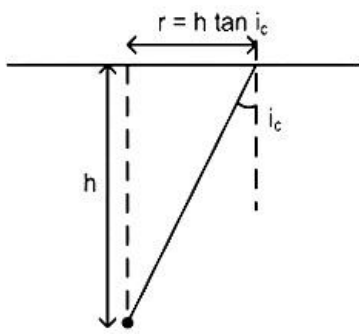

$$\text{So } r = h \frac{\sin i_c}{\sqrt{1 - \sin^2 i_c}}$$

$$\begin{aligned} \text{So } A &= \pi r^2 \\ &= \frac{\pi h^2 \sin^2 i_c}{1 - \sin^2 i_c} \\ &= \frac{\pi 7 \times \frac{9}{16}}{1 - \frac{9}{16}} = \frac{\pi \times 7 \times 9}{7} = 9\pi \end{aligned}$$

Question52

Consider a light ray travelling in air is incident into a medium of refractive index $\sqrt{2n}$. The incident angle is twice that of refracting angle. Then, the angle of incidence will be :
[27-Jun-2022-Shift-1]

Options:

- A. $\sin^{-1}(\sqrt{n})$
- B. $\cos^{-1}\left(\sqrt{\frac{n}{2}}\right)$
- C. $\sin^{-1}(\sqrt{2n})$
- D. $2\cos^{-1}\left(\sqrt{\frac{n}{2}}\right)$

Answer: D

Solution:

Solution:

According to the law,

$$1 \times \sin \theta = \sqrt{2n} \times \sin\left(\frac{\theta}{2}\right)$$

$$\Rightarrow \cos \frac{\theta}{2} = \sqrt{\frac{n}{2}}$$

$$\Rightarrow \theta = 2\cos^{-1}\left(\sqrt{\frac{n}{2}}\right)$$

Question53

A convex lens has power P. It is cut into two halves along its principal axis. Further one piece (out of the two halves) is cut into two halves perpendicular to the principal axis (as shown in figures). Choose the incorrect option for the reported pieces.

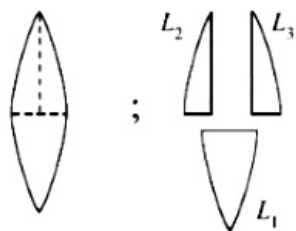

[27-Jun-2022-Shift-2]

Options:

A. Power of $L_1 = \frac{P}{2}$

B. Power of $L_2 = \frac{P}{2}$

C. Power of $L_3 = \frac{P}{2}$

D. Power of $L_1 = P$

Answer: A

Solution:

Solution:

We know $P = \frac{1}{f} = (\mu - 1) \left(\frac{1}{R_1} - \frac{1}{R_2} \right)$

$L_1 : \frac{1}{f_1} = (\mu - 1) \left(\frac{1}{R_1} - \frac{1}{R_2} \right) = P_1 = (\mu - 1) \left(\frac{2}{R} \right) = P$

$L_2 : \frac{1}{f_2} = (\mu - 1) \left(\frac{1}{R_1} \right) = P_2 = \frac{\mu - 1}{R}$

$L_3 : \frac{1}{f_3} = (\mu - 1) \left(-\frac{1}{R_2} \right) = P_3 = \frac{\mu - 1}{R}$

Question54

The refracting angle of a prism is A and refractive index of the material of the prism is $\cot(A / 2)$. Then the angle of minimum deviation will be -
[28-Jun-2022-Shift-1]

Options:

A. $180 - 2A$

B. $90 - A$

C. $180 + 2A$

D. $180 - 3A$

Answer: A

Solution:

Solution:

$$\mu = \frac{\sin\left(\frac{\delta_m + A}{2}\right)}{\sin(A/2)} = \cot A / 2$$

$$\Rightarrow \cos A / 2 = \sin\left(\frac{\delta_m + A}{2}\right)$$

$$\Rightarrow \frac{\pi}{2} - \frac{A}{2} = \frac{\delta_m + A}{2}$$

$$\Rightarrow \pi - 2A = \delta_m$$

Question55

The aperture of the objective is 24.4 cm. The resolving power of this telescope, if a light of wavelength 2440\AA is used to see the object will be : [28-Jun-2022-Shift-1]

Options:

A. 8.1×10^6

B. 10.0×10^7

C. 8.2×10^5

D. 1.0×10^{-8}

Answer: C

Solution:

Solution:

$$\begin{aligned} \text{R.P.} &= \frac{1}{1.22\lambda / a} \\ &= \frac{24.4 \times 10^{-2}}{1.22 \times 2440 \times 10^{-10}} \\ &= 8.2 \times 10^5 \end{aligned}$$

Question56

A parallel beam of light is allowed to fall on a transparent spherical globe of diameter 30 cm and refractive index 1.5. The distance from the centre of the globe at which the beam of light can converge is ____ mm. [29-Jun-2022-Shift-1]

Solution:

$$\text{1st refraction: } \frac{1.5}{v_1} - 0 = \frac{0.5}{15}$$

$$\Rightarrow v_1 = 45 \text{ cm}$$

$$\text{2nd refraction: } \frac{1}{v_2} - \frac{1.5}{15} = \frac{-0.5}{-15}$$

$$\Rightarrow \frac{1}{v_2} = \frac{1}{30} + \frac{1}{10}$$

$$= \frac{4}{30}$$

$$\Rightarrow v_2 = +7.5 \text{ cm}$$

$$\Rightarrow \text{Distance from centre} = 22.5 \text{ cm} = 225 \text{ mm}$$

Question57

The speed of light in media 'A' and 'B' are 2.0×10^{10} cm / s and 1.5×10^{10} cm / s respectively. A ray of light enters from the medium B to A at an incident angle ' θ '. If the ray suffers total internal reflection, then

[29-Jun-2022-Shift-2]

Options:

A. $\theta = \sin^{-1}\left(\frac{3}{4}\right)$

B. $\theta > \sin^{-1}\left(\frac{2}{3}\right)$

C. $\theta < \sin^{-1}\left(\frac{3}{4}\right)$

D. $\theta > \sin^{-1}\left(\frac{3}{4}\right)$

Answer: D

Solution:

Solution:

$$\mu_A = \frac{3 \times 10^8}{2 \times 10^8} = 1.5$$

$$\mu_B = \frac{3 \times 10^8}{1.5 \times 10^8} = 2$$

For TIR

$$\theta > i_c$$

$$\theta > \sin^{-1}\left(\frac{1.5}{2}\right)$$

$$\theta > \sin^{-1}\left(\frac{3}{4}\right)$$

Question58

Which of the following statement is correct?

[25-Jul-2022-Shift-1]

Options:

- A. In primary rainbow, observer sees red colour on the top and violet on the bottom
- B. In primary rainbow, observer sees violet colour on the top and red on the bottom
- C. In primary rainbow, light wave suffers total internal reflection twice before coming out of water drops.
- D. Primary rainbow is less bright than secondary rainbow.

Answer: A

Solution:

Solution:

In primary rainbow, observer sees red colour on the top and violet on the bottom.

Question59

Time taken by light to travel in two different materials A and B of refractive indices μ_A and μ_B of same thickness is t_1 and t_2 respectively. If $t_2 - t_1 = 5 \times 10^{-10}$ s and the ratio of μ_A to μ_B is 1 : 2. Then, the thickness of material, in meter is: (Given v_A and v_B are velocities of light in A and B materials respectively.)

[25-Jul-2022-Shift-1]

Options:

- A. $5 \times 10^{-10} v_A m$
- B. $5 \times 10^{-10} m$
- C. $1.5 \times 10^{-10} m$
- D. $5 \times 10^{-10} v_B m$

Answer: A

Solution:

Solution:

$$t_2 - t_1 = 5 \times 10^{-10}$$



$$\Rightarrow \frac{d}{v_B} - \frac{d}{v_A} = 5 \times 10^{-10}$$

$$\text{and, } \frac{v_B}{v_A} = \frac{\mu_A}{\mu_B} = \frac{1}{2}$$

$$\Rightarrow d \left(1 - \frac{v_B}{v_A} \right) = 5 \times 10^{-10} \times v_B$$

$$\Rightarrow d \left(1 - \frac{1}{2} \right) = 5 \times 10^{-10} \times v_B$$

$$\Rightarrow d = 10 \times 10^{-10} \times v_B \text{m}$$

$$\Rightarrow d = 5 \times 10^{-10} \times v_A \text{m}$$

Question60

For an object placed at a distance 2.4m from a lens, a sharp focused image is observed on a screen placed at a distance 12cm from the lens. A glass plate of refractive index 1.5 and thickness 1cm is introduced between lens and screen such that the glass plate plane faces parallel to the screen. By what distance should the object be shifted so that a sharp focused image is observed again on the screen?

[25-Jul-2022-Shift-2]

Options:

A. 0.8m

B. 3.2m

C. 1.2m

D. 5.6m

Answer: B

Solution:

Solution:

The shift produced by the glass plate is

$$d = t \left(1 - \frac{1}{\mu} \right) = 1 \times \left(1 - \frac{1}{1.5} \right) = \frac{1}{3} \text{cm}$$

So final image must be produced at $\left(12 - \frac{1}{3} \right) \text{cm} = \frac{35}{3} \text{cm}$ from lens so that glass plate must shift it to produce image at

screen. So

$$\frac{1}{12} - \frac{1}{-240} = \frac{1}{f} = \frac{1}{35/3} - \frac{1}{u}$$

$$\frac{1}{u} = \frac{3}{35} - \frac{1}{12} - \frac{1}{240}$$

or $u = -560 \text{cm}$

so shift = $5.6 - 2.4 = 3.2 \text{m}$

Question61

A convex lens of focal length 20cm is placed in front of a convex mirror with principal axis coinciding each other. The distance between the lens and mirror is 10cm. A point object is placed on principal axis at a

distance of 60cm from the convex lens. The image formed by combination coincides the object itself. The focal length of the convex mirror is ___ cm.

[25-Jul-2022-Shift-2]

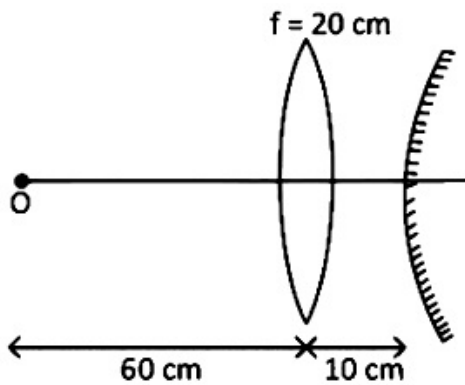

$$\frac{1}{v} + \frac{1}{u} = \frac{1}{f}$$

$$\frac{1}{v} - \frac{1}{-60} = \frac{1}{20}$$

$$\frac{1}{v} = -\frac{1}{60} + \frac{1}{20} = \frac{-1 + 3}{60} = \frac{2}{60}$$

$$\Rightarrow v = +30\text{cm}$$

$$\therefore \text{Radius of curvature of mirror} = 30 - 10 = 20\text{cm}$$

$$\Rightarrow f_{\text{mirror}} = \frac{20}{2} = 10\text{cm}$$

Question62

The graph between $\frac{1}{u}$ and $\frac{1}{v}$ for a thin convex lens in order to determine its focal length is plotted as shown in the figure. The refractive index of lens is 1.5 and its both the surfaces have same radius of curvature R.

The value of R will be _____ cm. (where u = object distance, v = image distance)

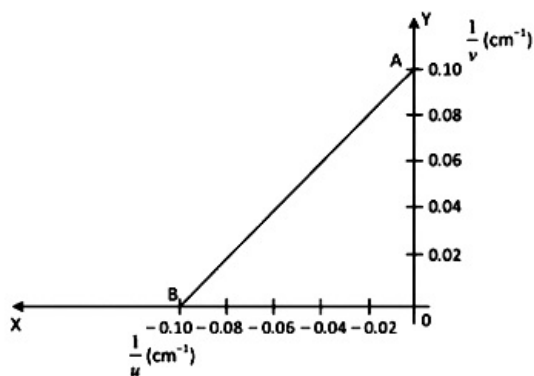

[26-Jul-2022-Shift-1]

Answer: 10

Solution:

$$f = 10 \text{ cm}$$

$$\frac{1}{f} = \frac{1}{R} - \frac{1}{-R}$$

$$\frac{1}{10} = \frac{1.5 - 1}{1} \times \frac{2}{R}$$

$$\frac{1}{10} = \frac{1}{R}$$

$$R = 10 \text{ cm}$$

Question 63

Light travels in two media M_1 and M_2 with speeds $1.5 \times 10^8 \text{ ms}^{-1}$ and $2.0 \times 10^8 \text{ ms}^{-1}$ respectively. The critical angle between them is :
[26-Jul-2022-Shift-2]

Options:

A. $\tan^{-1} \left(\frac{3}{\sqrt{7}} \right)$

B. $\tan^{-1} \left(\frac{2}{3} \right)$

C. $\cos^{-1} \left(\frac{3}{4} \right)$

D. $\sin^{-1} \left(\frac{2}{3} \right)$

Answer: A

Solution:

Solution:

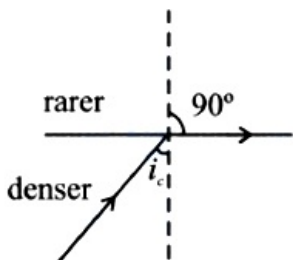

$$v = \frac{c}{n}$$

$$n_d \sin i_c = n_r \sin 90^\circ$$

$$\sin i_c = \frac{n_r}{n_d} = \frac{V_d}{V_r}$$

$$\sin i_c = \frac{1.5 \times 10^8}{2 \times 10^8} = \frac{1.5}{2}$$

$$\sin i_c = \frac{3}{4}$$

$$\tan i_c = \frac{3}{\sqrt{4^2 - 3^2}} \Rightarrow \frac{3}{\sqrt{7}}$$

$$i_c = \tan^{-1} \left(\frac{3}{\sqrt{7}} \right)$$

Question 64

In the given figure, the face AC of the equilateral prism is immersed in a liquid of refractive index 'n'. For incident angle 60° at the side AC, the refracted light beam just grazes along face AC. The refractive index of the liquid $n = \frac{\sqrt{x}}{4}$. The value of x is _____.

(Given refractive index of glass = 1.5)

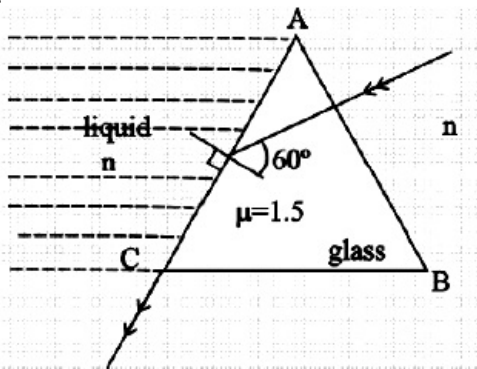

[26-Jul-2022-Shift-2]

Answer: 27

Solution:

Solution:

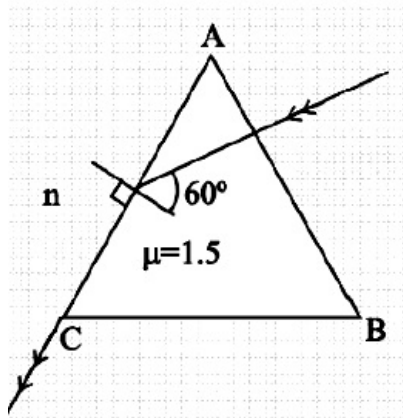

Using snell's law at face AC

$$1.5 \sin 60^\circ = n \times \sin 90^\circ$$

$$1.5 \times \frac{\sqrt{3}}{2} = n = \frac{\sqrt{x}}{4}$$

$$3\sqrt{3} = \sqrt{x}$$

$$x = 27$$

Question65

A microscope was initially placed in air (refractive index 1). It is then immersed in oil (refractive index 2). For a light whose wavelength in air is λ , calculate the change of microscope's resolving power due to oil and choose the correct option.

[27-Jul-2022-Shift-1]

Options:

- A. Resolving power will be $\frac{1}{4}$ in the oil than it was in the air.
- B. Resolving power will be twice in the oil than it was in the air.
- C. Resolving power will be four times in the oil than it was in the air.
- D. Resolving power will be $\frac{1}{2}$ in the oil than it was in the air.

Answer: B

Solution:

Solution:

$$\therefore \text{Resolving power} = \frac{2\mu \sin \theta}{1.22\lambda}$$

$$\frac{P_1}{P_2} = \frac{\mu_1}{\mu_2} \times \frac{\mu_1}{\mu_2}$$

$$= \left(\frac{\mu_1}{\mu_2} \right)^2$$

$$\Rightarrow \frac{P_1}{P_2} = \frac{1}{4}$$

$$\Rightarrow P_2 = 4P_1$$

Question66

A thin prism of angle 6° and refractive index for yellow light (n_Y) 1.5 is combined with another prism of angle 5° and $n_Y = 1.55$. The combination produces no dispersion. The net average deviation (δ) produced by the combination is $\left(\frac{1}{x} \right)^\circ$. The value of x is _____.

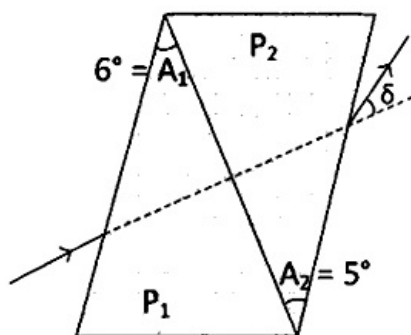

[27-Jul-2022-Shift-2]

Answer: 4

Solution:

$$\delta_{\text{net}} = \delta_1 + \delta_2$$
$$= |(\mu_1 - 1)A_1 - (\mu_2 - 1)A_2|$$
$$= |3^\circ - 2.75^\circ|$$
$$\delta_{\text{net}} = \frac{1^\circ}{4}$$
$$\Rightarrow x = 4$$

Question67

As shown in the figure, after passing through the medium 1 . The speed of light v_2 in medium 2 will be:

(. Given . $c = 3 \times 10^8 \text{ms}^{-1}$)

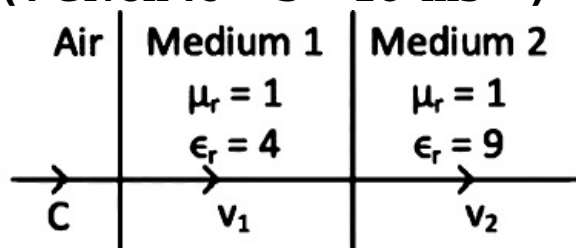

[28-Jul-2022-Shift-1]

Options:

- A. $1.0 \times 10^8 \text{ms}^{-1}$
- B. $0.5 \times 10^8 \text{ms}^{-1}$
- C. $1.5 \times 10^8 \text{ms}^{-1}$
- D. $3.0 \times 10^8 \text{ms}^{-1}$

Answer: A

Solution:

Solution:

$$V = \frac{1}{\sqrt{\mu\epsilon}} = \frac{1}{\sqrt{\mu_r \epsilon_r \mu_0 \epsilon_0}}$$
$$\Rightarrow V_2 = \frac{c}{\sqrt{9}} = 10^8 \text{m / s}$$

Question68

In normal adjustment, for a refracting telescope, the distance between objective and eye piece is 30 cm. The focal length of the objective, when

**the angular magnification of the telescope is 2 , will be
[28-Jul-2022-Shift-1]**

Options:

- A. 20 cm
- B. 30 cm
- C. 10 cm
- D. 15 cm

Answer: A

Solution:

Solution:

$$\therefore m = \frac{f_o}{f_e}$$
$$\Rightarrow 2 = \frac{f_o}{f_e} \dots\dots (i)$$

and, $l = f_o + f_e$

$$\Rightarrow 30 = f_o + f_e \dots\dots (ii)$$

$$\Rightarrow 30 = f_o + \frac{f_o}{2}$$

$$\Rightarrow 30 \times \frac{2}{3} = f_o$$

$$\Rightarrow f_o = 20 \text{ cm}$$

Question69

**The power of a lens (biconvex) is 1.25m^{-1} in particular medium. Refractive index of the lens is 1.5 and radii of curvature are 20 cm and 40 cm respectively. The refractive index of surrounding medium:
[28-Jul-2022-Shift-2]**

Options:

- A. 1.0
- B. $\frac{9}{7}$
- C. $\frac{3}{2}$
- D. $\frac{4}{3}$

Answer: B

Solution:

Solution:

$$P = \frac{\mu_2}{f} = (\mu_1 - \mu_2) \left(\frac{1}{R_1} - \frac{1}{R_2} \right) \quad (\text{For this formula refer to NCERT Part-2, Chapter-9, solved example 8})$$

(μ_1 is refractive index of lens and μ_2 is of surrounding medium)

$$1.25 = (1.5 - \mu_2) \left(\frac{1}{0.2} + \frac{1}{0.4} \right)$$

$$\frac{1.25 \times 0.08}{0.6} = (1.5 - \mu_2)$$

$$\Rightarrow \mu_2 = \frac{4}{3}$$

Question70

An object 'O' is placed at a distance of 100 cm in front of a concave mirror of radius of curvature 200 cm as shown in the figure. The object starts moving towards the mirror at a speed 2 cm / s. The position of the image from the mirror after 10 s will be at ___ cm.

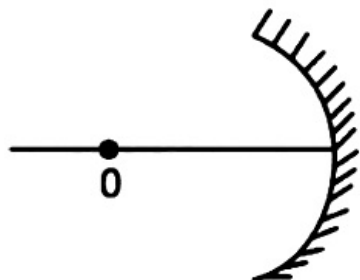

[28-Jul-2022-Shift-2]

Answer: 400

Solution:

Solution:

After 10 sec.

$$u = -80 \text{ cm}$$

$$f = -100 \text{ cm}$$

$$\frac{1}{v} + \frac{1}{u} = \frac{1}{f}$$

$$v = 400 \text{ cm}$$

Question71

The X - Y plane be taken as the boundary between two transparent media M_1 and M_2 . M_1 in $Z \geq 0$ has a refractive index of $\sqrt{2}$ and M_2 with $Z < 0$ has a refractive index of $\sqrt{3}$. A ray of light travelling in M_1 along the direction given by the vector $\vec{P} = 4\sqrt{3}\hat{i} - 3\sqrt{3}\hat{j} - 5\hat{k}$, is incident on the plane of separation. The value of difference between the angle of incident in M_1 and the angle of refraction in M_2 will be ___ degree.

[29-Jul-2022-Shift-1]



Answer: 15

Solution:

Solution:

$$\vec{A} = 4\sqrt{3}\hat{i} - 3\sqrt{3}\hat{j} - 5\hat{k}$$

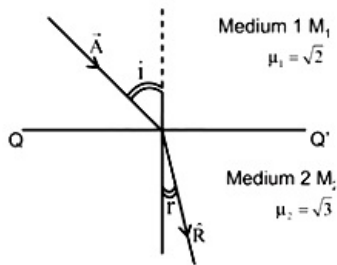

$$\mu_1 \sin i = \mu_2 \sin r$$

As incident vector A makes i angle with normal z -axis & refracted vector R makes r angle with normal z -axis with help of direction cosine

$$i = \cos^{-1} \left(\frac{A_z}{A} \right) = \cos^{-1} \left(\frac{5}{\sqrt{(4\sqrt{3})^2 + (3\sqrt{3})^2 + 5^2}} \right)$$

$$= \cos^{-1} \left(\frac{5}{10} \right) \Rightarrow i = 60^\circ$$

$$\sqrt{2} \sin 60 = \sqrt{3} \times \sin r$$

$$r = 45^\circ$$

$$\text{Difference between } i \text{ \& } r = 60 - 45 = 15$$

Question72

Light enters from air into a given medium at an angle of 45° with interface of the air-medium surface. After refraction, the light ray is deviated through an angle of 15° from its original direction. The refractive index of the medium is:

[29-Jul-2022-Shift-2]

Options:

A. 1.732

B. 1.333

C. 1.414

D. 2.732

Answer: C

Solution:

Solution:

Let, refractive index of medium = μ

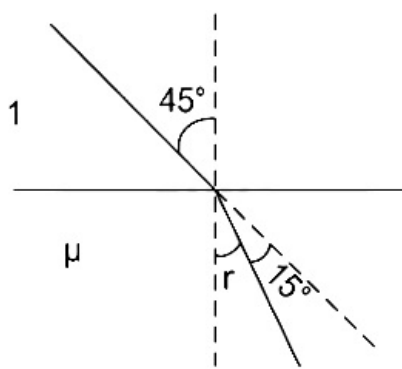

$$\therefore r + 15^\circ = 45^\circ$$

$$\Rightarrow r = 30^\circ$$

Using Snell's law,

$$1 \cdot \sin 45^\circ = \sin 30^\circ \times \mu$$

$$\Rightarrow \frac{1}{\sqrt{2}} = \frac{1}{2} \times \mu$$

$$\Rightarrow \mu = \frac{2}{\sqrt{2}} = \sqrt{2} = 1.414$$

Question73

The focal length f is related to the radius of curvature r of the spherical convex mirror by :
[24feb2021shift1]

Options:

A. $f = +\frac{1}{2}r$

B. $f = -r$

C. $f = -\frac{1}{2}r$

D. $f = r$

Answer: A

Solution:

Solution:

For convex mirror, focus is behind the mirror. So, its focal length (f) is positive. $\therefore f = +\frac{r}{2}$

Question74

The incident ray, reflected ray and the outward drawn normal are denoted by the unit vectors a , b and c , respectively. Then, choose the correct relation for these vectors.
[26 Feb 2021 Shift 2]

Options:

A. $b = a + 2c$

B. $b = 2a + c$

C. $b = a - 2(a \cdot c)c$

D. $b = a - c$

Answer: C

Solution:

Solution:

Taking component of a , b and c along \hat{i} , \hat{j} and \hat{k} .

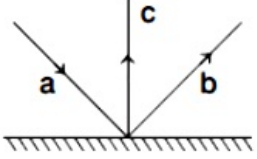

$$a = \sin\theta \hat{i} - \cos\theta \hat{j}$$

$$b = \sin\theta \hat{i} + \cos\theta \hat{j}$$

$$c = \hat{j}$$

Now, on solving option (c), we get

$$\begin{aligned} a - 2(a \cdot c)c &= (\sin\theta \hat{i} - \cos\theta \hat{j}) - 2[(\sin\theta \hat{i} - \cos\theta \hat{j}) \cdot \hat{j}] \hat{j} \\ &= \sin\theta \hat{i} + \cos\theta \hat{j} \\ &= b \end{aligned}$$

Question 75

A point source of light S , placed at a distance 60cm in front of the centre of a plane mirror of width 50cm, hangs vertically on a wall. A man walks in front of the mirror along a line parallel to the mirror at a distance 1.2m from it (see in the figure). The distance between the extreme points, where he can see the image of the light source in the mirror is cm.

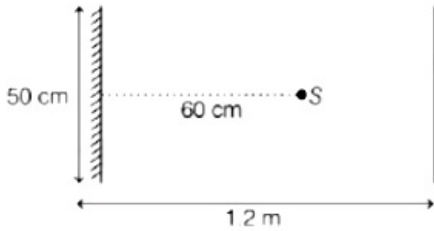

[26 Feb 2021 Shift 2]

Solution:

Given, length of mirror, $m = 50\text{cm} = 50 \times 10^{-2}\text{m}$

Distance of source from mirror, $d = 60\text{cm}$

$= 60 \times 10^{-2}\text{m}$ Distance of man from mirror, $d_m = 1.2\text{m}$

he concept of ray diagram of plane mirror shown below

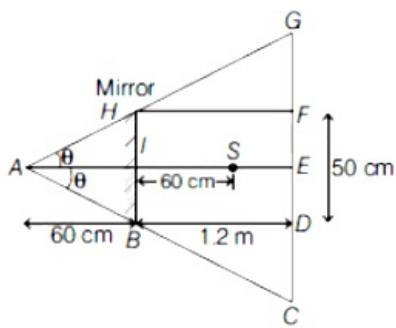

Now, using the concept of similar triangle,
 $\Delta HAI \sim \Delta GAE$ and $\Delta BAI \sim \Delta CAE$

$$\therefore \frac{AI}{AE} = \frac{HI}{EG}$$

$$\Rightarrow \frac{0.60}{1.8} = \frac{0.25}{EG}$$

$$\Rightarrow EG = 0.25 \times \frac{1.8}{0.6} = 0.25 \times 3 = 0.75\text{m}$$

As, $CG = 2EG$

$$\Rightarrow CG = 0.75 \times 2 = 1.50\text{m}$$

$$\frac{AI}{AE} = \frac{HI}{EG}$$

$$\Rightarrow \frac{0.60}{1.8} = \frac{0.25}{EG}$$

$$\Rightarrow EG = 0.25 \times \frac{1.8}{0.6} = 0.25 \times 3 = 0.75\text{m}$$

As, $CG = 2EG$

$$\Rightarrow CG = 0.75 \times 2 = 1.50\text{m}$$

Hence, distance between the extreme points, where he can see image of light source in mirror is 150cm.

Question 76

A short straight object of height 100cm lies before the central axis of a spherical mirror, whose focal length has absolute value $f = 40\text{cm}$. The image of object produced by the mirror is of height 25cm and has the same orientation of the object. One may conclude from the information. [26 Feb 2021 Shift 1]

Options:

- A. Image is real, same side of concave mirror
- B. Image is virtual, opposite side of concave mirror
- C. Image is real, same side of convex mirror
- D. Image is virtual, opposite side of convex mirror

Answer: D

Solution:

Solution:

Given, height of object, $h_o = 100\text{cm}$

Focal length of mirror, $f = 40\text{cm}$

Height of image, $h_i = 25\text{cm}$

Nature of image is erect means virtual.

As, h_i is less than h_o ,

so mirror used is convex mirror.

Hence, (d) is correct option, i.e. image is virtual, opposite and is convex.

Question77

The same size images are formed by a convex lens when the object is placed at 20cm or at 10cm from the lens. The focal length of convex lens is cm.

[25 Feb 2021 Shift 1]

Answer: 15

Solution:

Solution:

Let v be the position of image, h be the height of image and h_o be the height of object.

Given, $h_i = h_o$

Since, magnification, $m = h_i / h_o = h_i / h \dots (i)$

By using lens formula,

$$1/f = 1/v - 1/u \Rightarrow 1/v = 1/f + 1/u$$

$$v = \frac{fu}{u+f}$$

$$m = \frac{v}{u} = \frac{f}{f+u}$$

Now, from Eq. (i), m can be ± 1 .

$$\text{For, } m = +1 = \frac{f}{-10+f} \dots (ii)$$

$$\text{For } m = -1 = \frac{f}{-20+f} \dots (iii)$$

On dividing Eq. (iii) by Eq. (ii), we get

$$-1 = \frac{-10+f}{-20+f}$$

$$\Rightarrow 20 - f = -10 + f \Rightarrow 30 = 2f$$

$$\Rightarrow f = 15\text{cm}$$

Question78

Given below are two statements: one is labelled as Assertion (A) and the other is labelled as Reason (R).

Assertion (A) For a simple microscope, the angular size of the object equals the angular size of the image.

Reason (R) Magnification is achieved as the small object can be kept much closer to the eye than 25cm and hence, it subtends a large angle.

In the light of the above statements, choose the most appropriate answer from the options given below.

[26 Feb 2021 Shift 2]

Options:

A. A is true but R is false.

B. Both A and R are true but R is not the correct explanation of A.

C. Both A and R are true and R is the correct explanation of A.



D. A is false but R is true.

Answer: C

Solution:

Solution:

The formation of image with simple microscope is shown below.

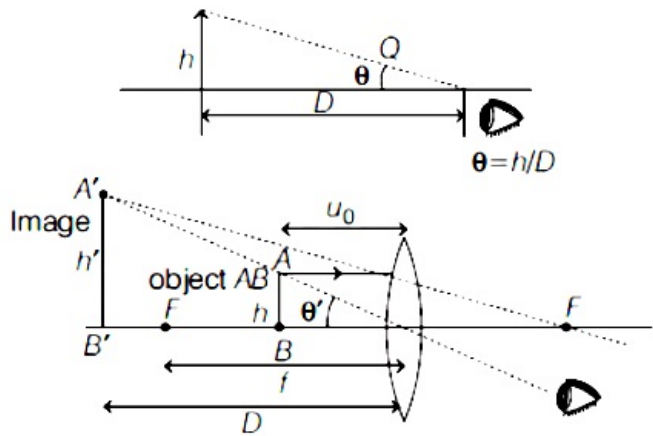

$$\text{Here, } \theta = \frac{h}{u_0} = \frac{h'}{D} = \frac{h'}{25}$$

where, $D = 25\text{cm}$ (least distance of distinct vision)

Here, θ is same for both object and image, hence Assertion is true.

$$\text{Magnification, } m = \frac{\theta'}{\theta} = \frac{D}{u_0}$$

Hence, if $u_0 < D(25\text{cm})$, hence the value of θ' will obtain large. So, option (c) is the correct.

Question 79

Three rays of light, namely red (R), green (G) and blue (B) are incident on the face PQ of a right angled prism PQR as shown in figure

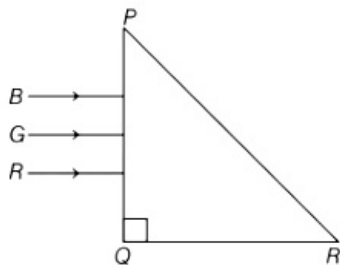

The refractive indices of the material of the prism for red, green and blue wavelength are 1.27, 1.42 and 1.49, respectively. The colour of the ray(s) emerging out of the face PR is
[18 Mar 2021 Shift 2]

Options:

- A. green
- B. red
- C. blue and green
- D. blue

Answer: B



Solution:

Solution:

From the given figure,

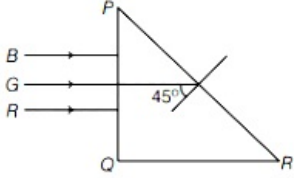

We know that,

$$\mu = \frac{1}{\sin i_c}$$

Here, i_c is the critical angle of incidence and μ is the refractive index.

$$\mu = \frac{1}{\sin 45^\circ} \Rightarrow \mu = 1.414$$

The rays will emerge out when angle of incidence is less than the angle of critical angle of glass-air interface PR.

As $\mu_R < \mu$ while μ_G and $\mu_B > \mu$, so only red colour will be transmitted through face PR while green and blue rays will suffer total internal reflection.

Question80

The angle of deviation through a prism is minimum when

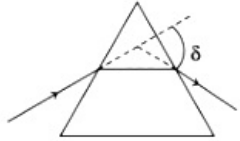

- A. incident ray and emergent ray are symmetric to the prism
- B. the refracted ray inside the prism becomes parallel to its base
- C. angle of incidence is equal to that of the angle of emergence
- D. angle of emergence is double the angle of incidence

Choose the correct answer from the options given below.

[16 Mar 2021 Shift 1]

Options:

- A. Statements (A), (B) and (C) are true.
- B. Only statement (D) is true.
- C. Only statements (A) and (B) are true.
- D. Statements (B) and (C) are true.

Answer: A

Solution:

Solution:

The propagation of light ray from a prism is shown below



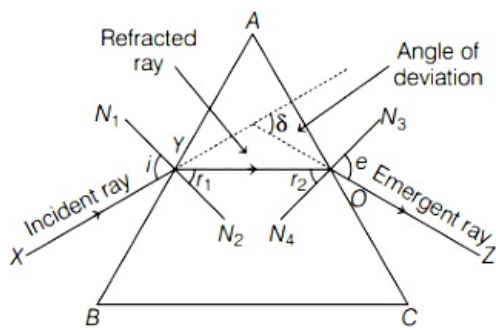

From the above figure, we can say that minimum value of angle of deviation can only be achieved when
 A. incident ray and emergent ray are symmetric to the prism.
 B. the refracted ray inside the prism becomes parallel to its base.
 C. angle of incidence is equal to angle of emergence.
 \therefore Statement (A), (B) and (C) are true.
 Note Refracted ray inside the prism is parallel to the base only for equilateral and isosceles prism.

Question81

The image of an object placed in air formed by a convex refracting surface is at a distance of 10m behind the surface. The image is real and is at $\frac{2}{3}$ of the distance of the object from the surface .The wavelength of light inside the surface is $\frac{2}{3}$ times the wavelength in air. The radius of the curved surface is $\frac{x}{13}$ m. The value of x is [17 Mar 2021 Shift 2]

Answer: 30

Solution:

Solution:

Given,

Image distance, $v = 10\text{m}$

Object distance, $u = \left(\frac{3}{2}\right) \times 10 = 15\text{m}$

and $n_2 = \frac{3}{2}n_1$ ($\because n \propto \frac{1}{\lambda}$)

Using the lens Maker's formula,

$$\frac{n_2}{v} - \frac{n_1}{u} = \left(\frac{n_2 - n_1}{R}\right)$$

Substituting the values in the above equation, we get

$$\frac{\frac{3}{2}n_1}{10} - \frac{n_1}{-15} = \left(\frac{\frac{3}{2}n_1 - n_1}{R}\right) \Rightarrow R = \frac{30}{13}\text{m}$$

The radius of the curved surface is $\frac{30}{13}\text{m}$.

Comparing with $\frac{x}{13}$, we get

$x = 30$

Question82

Red light differs from blue light as they have [16 Mar 2021 Shift 2]

Options:

- A. different frequencies and different wavelengths
- B. different frequencies and same wavelengths
- C. same frequencies and same wavelengths
- D. same frequencies and different wavelengths

Answer: A

Solution:

Solution:

Since, $\lambda v = c = \text{constant}$

where, $\lambda = \text{wavelength of light}$

and $v = \text{frequency of light.}$

Red light and blue light have different wavelengths and different frequencies but same speed.

Question83

A deviation of 2° is produced in the yellow ray when prism of crown and flint glass are achromatically combined. Taking dispersive powers of crown and flint glass are 0.02 and 0.03 respectively and refractive index for yellow light for these glasses are 1.5 and 1.6, respectively. The refracting angles for crown glass prism will be (in degree). (Round off to the nearest integer)
[16 Mar 2021 Shift 2]

Answer: 12

Solution:

Solution:

Given

Dispersive power of crown glass, $\omega_1 = 0.02$

Dispersive power of flint glass, $\omega_2 = 0.03$

Refractive index of yellow light,

for crown glass, $\mu_1 = 1.5$ and

for flint glass, $\mu_2 = 1.6$

This is a case of achromatic combination.

$$\therefore \theta_{\text{net}} = 0$$

$$\Rightarrow \theta_1 - \theta_2 = 0 \Rightarrow \theta_1 = \theta_2$$

$$\Rightarrow \omega_1 \delta_1 = \omega_2 \delta_2 \quad [\because \theta = \omega \delta] \dots (i)$$

$$\text{and } \delta_{\text{net}} = \delta_1 - \delta_2 = 2^\circ \dots \dots (ii)$$

From Eqs. (i) and (ii), we get

$$\delta_1 - \frac{\omega_1 \delta_1}{\omega_2} = 2^\circ$$

$$\Rightarrow \delta_1 \left(1 - \frac{\omega_1}{\omega_2} \right) = 2^\circ \Rightarrow \delta_1 \left(1 - \frac{2}{3} \right) = 2^\circ$$

$$\Rightarrow \delta_1 = 6^\circ$$

$$\text{Also, } \delta_1 = (\mu_1 - 1)A_1$$

$$\Rightarrow 6^\circ = (1.5 - 1)A_1 \Rightarrow A_1 = 12^\circ$$

\therefore The refracting angle for crown glass prism will be 12° .

Question 84

The thickness at the centre of a plano convex lens is 3mm and the diameter is 6cm. If the speed of light in the material of the lens is $2 \times 10^8 \text{ms}^{-1}$, then the focal length of the lens is [17 Mar 2021 Shift 1]

Options:

- A. 0.30cm
- B. 15cm
- C. 1.5cm
- D. 30cm

Answer: D

Solution:

Solution:

Given, thickness at the centre of plano-convex lens, $t = 3\text{mm} = 3 \times 10^{-3}\text{m}$

Diameter of plano-convex lens, $d = 6\text{cm}$

\therefore Radius of plano-convex lens, $r = 3\text{cm} = 3 \times 10^{-2}\text{m}$

Speed of light in lens material, $v = 2 \times 10^8 \text{ms}^{-1}$

$$\text{Refractive index} = \frac{\text{Speed of light in air}}{\text{Speed of light in medium}}$$

$$\mu = \frac{3 \times 10^8}{2 \times 10^8} = \frac{3}{2} = 1.5$$

$$\Rightarrow \mu = 1.5$$

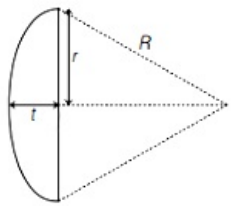

We know that, $R^2 = (R - t)^2 + r^2$

where, R is the radius of curvature of plano convex lens.

$$\Rightarrow R^2 = R^2 + t^2 - 2Rt + r^2 \Rightarrow 2Rt = r^2 + t^2$$

As, t is small, then t^2 will be very very small, so it can be neglected.

$$\Rightarrow 2Rt = r^2$$

$$\Rightarrow R = r^2/2t \dots (i)$$

From lens Maker's formula, we have

$$\frac{1}{f} = (\mu - 1) \left(\frac{1}{R_1} - \frac{1}{R_2} \right)$$

Here $R_1 = R$ & $R_2 = \infty$

$$\Rightarrow \frac{1}{f} = (\mu - 1) \left(\frac{1}{R} - \frac{1}{\infty} \right)$$

$$\Rightarrow \frac{1}{f} = \frac{\mu - 1}{R} \dots (ii)$$

From Eqs. (i) and (ii), we get

$$\frac{1}{f} = \frac{\mu - 1(2t)}{r^2} \Rightarrow f = \frac{r^2}{(\mu - 1)2t}$$

Putting the given values in above equation, we get

$$f = \frac{(3 \times 10^{-2})^2}{(1.5 - 1)2 \times 3 \times 10^{-3}} \Rightarrow f = 0.3\text{m}$$

$$f = 30\text{cm}$$

Question85

The refractive index of a converging lens is 1.4. What will be the focal length of this lens if it is placed in a medium of same refractive index? (Assume the radii of curvature of the faces of lens are R_1 and R_2 respectively)

[16 Mar 2021 Shift 2]

Options:

- A. 1
- B. Infinite
- C. $\frac{R_1 R_2}{R_1 - R_2}$
- D. Zero

Answer: B

Solution:

Solution:

Consider a convex lens of refractive index μ_2 and μ_1 is the refractive index of the medium in which it is placed.



$$\Rightarrow \mu_2 = \mu_1 \dots (i)$$

According to the lens Maker's formula,

$$\frac{1}{f} = \left[\frac{\mu_1}{\mu_2} - 1 \right] \left[\frac{1}{R_1} - \frac{1}{R_2} \right] \dots (ii)$$

where, f is the focal length of the lens,

R_1 and R_2 are the radii of curvature of respective faces of lens.

From Eqs. (i) and (ii), we can write

$$\frac{1}{f} = [1 - 1] \left[\frac{1}{R_1} - \frac{1}{R_2} \right] = 0$$

$$\Rightarrow \frac{1}{f} = 0 \Rightarrow f = \text{Infinite}$$

Question86

Your friend is having eye sight problem. She is not able to see clearly a distant uniform window mesh and it appears to her as non-uniform and distorted. The doctor diagnosed the problem as

Options:

- A. astigmatism
- B. myopia with astigmatism
- C. presbyopia with astigmatism
- D. myopia and hypermetropia

Answer: B

Solution:

Solution:

A friend is not seen clearly the distant object, then its diagnosis is myopia because in myopia the distant object is blurry and it also appear non-uniform and distorted images of the object, then its diagnosis is astigmatism also.

Question87

The expected graphical representation of the variation of angle of deviation ' δ ' with angle of incidence ' i ' in a prism is :
[27 Jul 2021 Shift 2]

Options:

A.

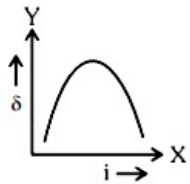

B.

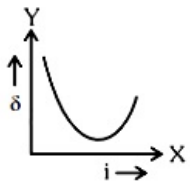

C.

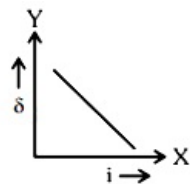

D.



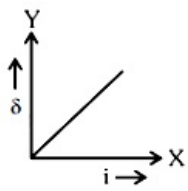

Answer: B

Solution:

Solution:

Standard graph between angle of deviation and incident angle.

Question88

A prism of refractive index n_1 and another prism of refractive index n_2 are stuck together (as shown in the figure). n_1 and n_2 depend on λ , the wavelength of light, according to the relation

$$n_1 = 1.2 + \frac{10.8 \times 10^{-14}}{\lambda^2} \text{ and } n_2 = 1.45 + \frac{1.8 \times 10^{-14}}{\lambda^2}$$

The wavelength for which rays incident at any angle on the interface BC pass through without bending at that interface will be _____ nm.

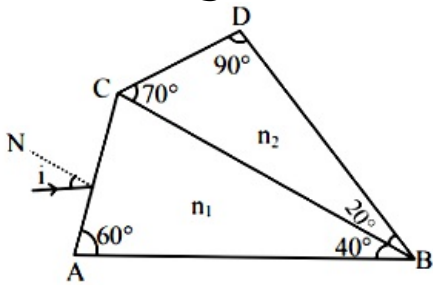

[27 Jul 2021 Shift 1]

Answer: 600

Solution:

Solution:

For no bending, $n_1 = n_2$

$$1.2 + \frac{10.8 \times 10^{-14}}{\lambda^2} = 1.45 + \frac{1.8 \times 10^{-14}}{\lambda^2}$$

On solving,

$$9 \times 10^{-14} = 25\lambda^2$$

$$\lambda = 6 \times 10^{-7}$$

$$\lambda = 600\text{nm}$$

Question89



A ray of light entering from air into a denser medium of refractive index $\frac{4}{3}$, as shown in figure. The light ray suffers total internal reflection at the adjacent surface as shown. The maximum value of angle theta should be equal to :

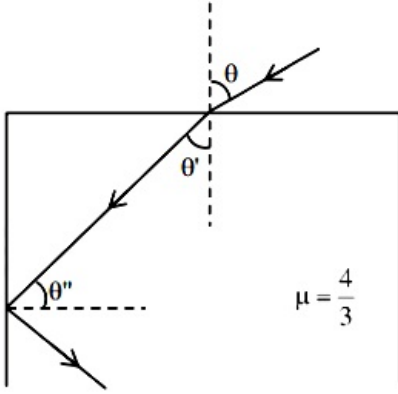

[25 Jul 2021 Shift 2]

Options:

- A. $\sin^{-1} \frac{\sqrt{5}}{4}$
- B. $\sin^{-1} \frac{\sqrt{7}}{3}$
- C. $\sin^{-1} \frac{\sqrt{5}}{3}$
- D. $\sin^{-1} \frac{\sqrt{7}}{4}$

Answer: A

Solution:

Solution:

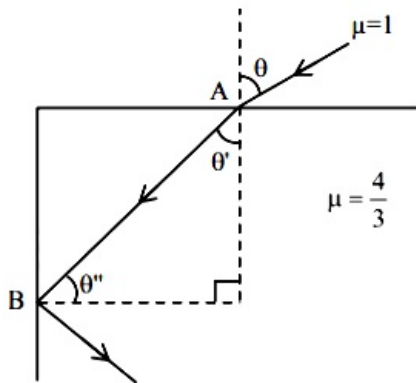

At maximum angle θ ray at point B goes in grazing emergence, at all less values of θ , TIR occurs.

At point B

$$\frac{4}{3} \times \sin \theta'' = 1 \times \sin 90^\circ$$

$$\theta'' = \sin^{-1} \left(\frac{3}{4} \right)$$

$$\theta' = \left(\frac{\pi}{2} - \theta'' \right)$$

At point A

$$1 \times \sin \theta = \frac{4}{3} \times \sin \theta'$$

$$\sin \theta = \frac{4}{3} \times \sin \left(\frac{\pi}{2} - \theta'' \right)$$

$$\sin \theta = \frac{4}{3} \cos \left[\cos^{-1} \frac{\sqrt{7}}{4} \right]$$

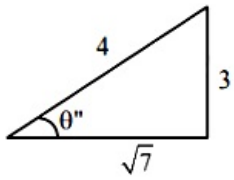

$$\sin \theta = \frac{4}{3} \times \frac{\sqrt{7}}{4}$$

$$\theta = \sin^{-1} \left(\frac{\sqrt{7}}{3} \right)$$

Question90

A ray of laser of a wavelength 630 nm is incident at an angle of 30° at the diamond-air interface. It is going from diamond to air. The refractive index of diamond is 2.42 and that of air is 1. Choose the correct option.

[25 Jul 2021 Shift 1]

Options:

- A. angle of refraction is 24.41°
- B. angle of refraction is 30°
- C. refraction is not possible
- D. angle of refraction is 53.4°

Answer: C

Solution:

Solution:

$$\sin \theta_c = \frac{1}{\mu} = \frac{1}{2.42} < \sin \theta_c$$

$$\sin \theta > \sin \theta_c$$

$$\theta > \theta_c$$

Total internal reflection will happen

Question91

A ray of light passes from a denser medium to a rarer medium at an angle of incidence i . The reflected and refracted rays make an angle of 90° with each other. The angle of reflection and refraction are respectively r and r' . The critical angle is given by :

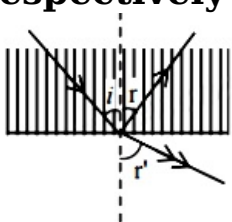

[22 Jul 2021 Shift 2]

Options:

- A. $\sin^{-1}(\cot r)$
- B. $\tan^{-1}(\sin i)$
- C. $\sin^{-1}(\tan r)$
- D. $\sin^{-1}(\tan r)$

Answer: D

Solution:

$$: 180^\circ \Rightarrow r' = 90 - r = 90 - i$$
$$\text{in } r' = n_2 \sin(90 - i)$$

$$n_1 \sin i = n_2 \cos i \Rightarrow \tan i = \frac{n_2}{n_1}$$

$$\text{Now } \sin C = \frac{n_2}{n_1} = \tan i$$

$$\Rightarrow C = \sin^{-1}(\tan i) = \sin^{-1}(\tan r)$$

Question92

A ray of light passing through a prism ($\mu = \sqrt{3}$) suffers minimum deviation. It is found that the angle of incidence is double the angle of refraction within the prism. Then, the angle of prism is _____ (in degrees)

[22 Jul 2021 Shift 2]

Answer: 60

Solution:

$$\text{At minimum deviation } r_1 = r_2 = \frac{A}{2}$$

$$\text{Also given } i = 2r_1 = A$$

$$\text{Now } 1 \cdot \sin i = \sqrt{3} \sin r_1$$

$$1 \sin A = \sqrt{3} \sin \frac{A}{2}$$

$$\Rightarrow 2 \sin \frac{A}{2} \cos \frac{A}{2} = \sqrt{3} \sin \frac{A}{2}$$

$$\Rightarrow \cos \frac{A}{2} = \frac{\sqrt{3}}{2} \Rightarrow \frac{A}{2} = 30^\circ$$

$$\Rightarrow A = 60^\circ$$



Question93

Region I and II are separated by a spherical surface of radius 25 cm. An object is kept in region I at a distance of 40 cm from the surface. The distance of the image from the surface is :

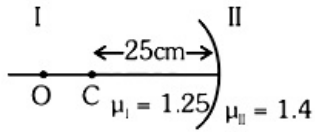

[20 Jul 2021 Shift 1]

Options:

- A. 55.44 cm
- B. 9.52 cm
- C. 18.23 cm
- D. 37.58 cm

Answer: D

Solution:

Solution:

$$\frac{\mu_2}{v} - \frac{\mu_1}{u} = \frac{\mu_2 - \mu_1}{R}$$
$$\frac{1.4}{v} - \frac{1.25}{-40} = \frac{1.4 - 1.25}{-25}$$
$$\frac{1.4}{v} = -\frac{0.15}{25} - \frac{1.25}{40}$$
$$v = -37.58\text{cm}$$

Hence option (4)

Question94

An object viewed from a near point distance of 25 cm, using a microscopic lens with magnification '6', gives an unresolved image. A resolved image is observed at infinite distance with a total magnification double the earlier using an eyepiece along with the given lens and a tube of length 0.6 m, if the focal length of the eyepiece is equal to _____ cm.

[20 Jul 2021 Shift 1]

Answer: 25

Solution:

For simple microscope,

$$m = 1 + \frac{D}{f_0}$$

$$6 = 1 + \frac{D}{f_0}$$

$$5 = \frac{25}{f_0}$$

$$f_0 = 5\text{cm}$$

For compound microscope,

$$m = \frac{1 \cdot D}{f_0 \cdot f_e}$$

$$12 = \frac{60 \times 25}{5 \cdot f_e}$$

$$f_e = 25\text{cm}$$

Question95

Two plane mirrors M_1 and M_2 are at right angle to each other shown. A point source P is placed at a and $2a$ meter away from M_1 and M_2 , respectively. The shortest distance between the images thus formed is (Take $\sqrt{5} = 2.3$)

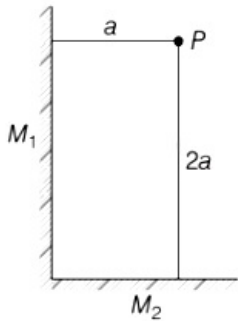

[31 Aug 2021 Shift 1]

Options:

- A. $3a$
- B. $4.6 a$
- C. $2.3 a$
- D. $2\sqrt{10}a$

Answer: B

Solution:

Solution:

According to the given figure, we have two plane mirror, placed at 90° to each other. Since, image formed by plane mirror are virtual, erect, same size and at same distance behind mirror. Let I_1 is the image of P due to mirror M_1 and I_2 is the image of P due to mirror M_2

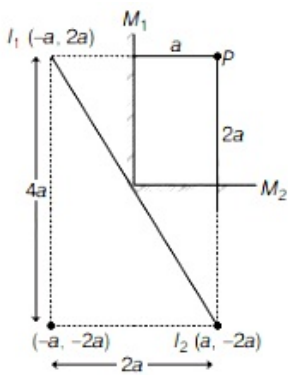

Therefore, the shortest distance between images i.e., between I_1 and I_2

$$\begin{aligned} I_1 I_2 &= \sqrt{(4a)^2 + (2a)^2} \\ &= \sqrt{16a^2 + 4a^2} \\ &= a\sqrt{20} = a2\sqrt{5} \\ &= a \times 2 \times 2.3 = 4.6a \end{aligned}$$

Question96

An object is placed beyond the centre of curvature C of the given concave mirror. If the distance of the object is d_1 from C and the distance of the image formed is d_2 from C, the radius of curvature of this mirror is

[27 Aug 2021 Shift 1]

Options:

A. $\frac{2d_1 d_2}{d_1 - d_2}$

B. $\frac{2d_1 d_2}{d_1 + d_2}$

C. $\frac{d_1 d_2}{d_1 + d_2}$

D. $\frac{d_1 d_2}{d_1 - d_2}$

Answer: A

Solution:

Solution:

The given situation is shown in the following ray diagram.

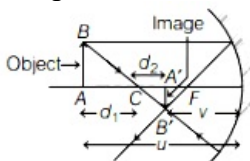

In concave mirror, when object is placed beyond C the image is formed between C and focus of mirror.

Consider radius of curvature of mirror is R.

Object distance, $u = -(R + d_1)$

Image distance, $v = -(R - d_2)$

Focal length of mirror, $f = \frac{-R}{2}$

Now, from mirror formula, we have

$$\frac{1}{f} = \frac{1}{v} + \frac{1}{u} = \frac{u + v}{uv}$$

$$\Rightarrow uv = f(u + v)$$

Substituting the values in above expression, we get

$$[-(R + d_1)][-(R - d_2)] = -\frac{R}{2}(R + d_1 + R - d_2)$$

$$\Rightarrow 2(R^2 - d_2R + d_1R - d_1d_2) = 2R^2 + d_1R - d_2R$$

$$\Rightarrow 2R^2 - 2d_2R + 2d_1R - 2R^2 - d_1R + d_2R = 2d_1d_2$$

$$\Rightarrow d_1R - d_2R = 2d_1d_2$$

$$\Rightarrow R = \frac{2d_1d_2}{d_1 - d_2}$$

Thus, radius of curvature of mirror is $\frac{2d_1d_2}{d_1 - d_2}$.

Question97

Car B overtakes another car A at a relative speed of 40ms^{-1} . How fast will the image of car B appear to move in the mirror of focal length 10 cm fitted in car A, when the car B is 1.9m away from the car A ? [26 Aug 2021 Shift 1]

Options:

A. 4ms^{-1}

B. 0.2ms^{-1}

C. 40ms^{-1}

D. 0.1ms^{-1}

Answer: D

Solution:

Solution:

According to the question,

Velocity of car B w.r.t. mirror of car A, $v_{BM} = 40\text{m/s}$

Distance of car B from mirror of car A, $u = 1.9\text{m} = 190\text{cm}$

Focal length of mirror, $f = 10\text{cm}$

We have to find the velocity of image of car B in the mirror, i.e. v_{IM}

We know that,

$$v_{IM} = -m^2v_{BM} \dots(i)$$

where, m is the magnification produced by mirror of car A,

$$\Rightarrow m = \frac{f}{f - u} = \frac{10}{10 - (-190)}$$

$$= \frac{10}{200} = \frac{1}{20}$$

Substituting the values in Eq. (i), we get

$$v_{IM} = -\left(\frac{1}{20}\right)^2 \times 40$$

$$= -\frac{1}{400} \times 40 = -0.1\text{m/s}$$

Here, negative sign shows that, the speed of image w.r.t. mirror of car A is in opposite direction.

Question98

Cross-section view of a prism is the equilateral triangle ABC in the

figure. The minimum deviation is observed using this prism when the angle of incidence is equal to the prism angle. The time taken by light to travel from P (mid-point of BC) to A is..... $\times 10^{-10}$ s.

(Given, speed of light in vacuum = 3×10^8 m / s and $\cos 30^\circ = \frac{\sqrt{3}}{2}$)

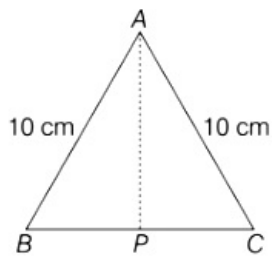

[31 Aug 2021 Shift 2]

Solution:

Solution:

Given, the base of a prism is equilateral triangle of side 10 cm as shown in figure.

At minimum deviation, Angle of incident = Angle of prism

i.e. $i = A = 60^\circ$

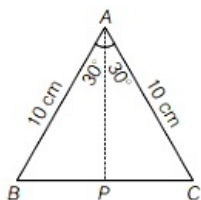

Angle of refraction, $r = \frac{A}{2} = 60^\circ / 2 = 30^\circ$

Let μ be the refractive index.

Then, by Snell's law of refraction,

$$\mu = \frac{\sin i}{\sin r} = \frac{\sin 60^\circ}{\sin 30^\circ} = \frac{\frac{\sqrt{3}}{2}}{\frac{1}{2}} = \sqrt{3}$$

Now, in $\triangle ABP$, $AP = AB \cos 30^\circ$

$$= \frac{10\sqrt{3}}{2} = 5\sqrt{3} \text{ cm}$$

$$= 5\sqrt{3} \times 10^{-2} \text{ m}$$

i.e. optical distance travelled by light along AP,

$$d = \mu \times AP = \sqrt{3} \times 5\sqrt{3} \times 10^{-2} = 15 \times 10^{-2} \text{ m}$$

Now, the time taken by light ($c = 3 \times 10^8$ m / s) to travel from P to A,

$$t = \frac{d}{C} = \frac{15 \times 10^{-2}}{3 \times 10^8} \text{ s} = 5 \times 10^{-10} \text{ s}$$

Thus, correct answer is 5.

Question99

An object is placed at the focus of concave lens having focal length f. What is the magnification and distance of the image from the optical centre of the lens?

[31 Aug 2021 Shift 1]

Options:

- A. 1, ∞
- B. Very high, ∞
- C. $\frac{1}{2}, \frac{f}{2}$
- D. $\frac{1}{4}, \frac{f}{4}$

Answer: C**Solution:****Solution:**

Given, focal length of concave lens, $f' = -f$

Object distance from lens, $u = -f$

Image distance from lens = v

Magnification = m

By using lens formula,

$$\frac{1}{f'} = \frac{1}{v} - \frac{1}{u}$$

$$\Rightarrow \frac{1}{v} = \frac{1}{f} + \frac{1}{u}$$

$$= -\frac{1}{f} - \frac{1}{f} = -\frac{2}{f}$$

$$\Rightarrow v = -\frac{f}{2}$$

$$\therefore |v| = \frac{f}{2}$$

$$\therefore m = \frac{v}{u} = \frac{-\frac{f}{2}}{-f} = \frac{1}{2}$$

Question100

Curved surfaces of a plano-convex lens of refractive index μ_1 and a plano-concave lens of refractive index μ_2 have equal radius of curvature as shown in figure. Find the ratio of radius of curvature to the focal length of the combined lenses.

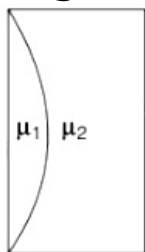
**[27 Aug 2021 Shift 2]****Options:**

- A. $\frac{1}{\mu_2 - \mu_1}$
- B. $\mu_1 - \mu_2$



C. $\frac{1}{\mu_1 - \mu_2}$

D. $\mu_2 - \mu_1$

Answer: B

Solution:

Solution:

Question 101

Find the distance of the image from object O, formed by the combination of lenses in the figure.

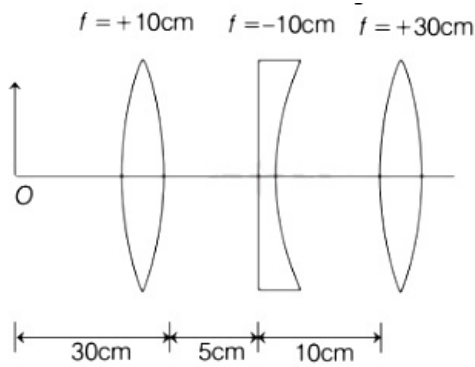

[27 Aug 2021 Shift 1]

Options:

- A. 75 cm
- B. 10 cm
- C. 20 cm
- D. infinity

Answer: A

Solution:

Solution:

Given, focal length of first lens, $f_1 = +10\text{ cm}$

Focal length of second lens, $f_2 = -10\text{ cm}$

Focal length of third lens, $f_3 = +30\text{ cm}$

Object distance from first lens, $u_1 = -30\text{ cm}$

Using lens formula for first lens, we get

$$\frac{1}{f_1} = \frac{1}{v_1} - \frac{1}{u_1}$$

$$\Rightarrow \frac{1}{-10} = \frac{1}{v_1} - \frac{1}{-30}$$

$$\Rightarrow \frac{1}{v_1} = \frac{1}{10} - \frac{1}{30} = \frac{2}{30}$$

$$v_1 = 15\text{ cm}$$

Thus, the image formed by first lens is 15 cm to the right of first lens.

The object distance for second lens will be

$$u_2 = 15 \text{ cm} - 5 \text{ cm} = 10 \text{ cm}$$

Using lens formula for first lens, we get

$$\frac{1}{f_2} = \frac{1}{v_2} - \frac{1}{u_2}$$

$$\Rightarrow \frac{1}{-10} = \frac{1}{v_2} - \frac{1}{10}$$

$$\Rightarrow \frac{1}{v_2} = \frac{1}{-10} + \frac{1}{10} = 0$$

$$\Rightarrow v_2 = \infty$$

Thus, the object distance for third lens, $u_3 = \infty$.

Using lens formula for third lens, we get

$$\frac{1}{f_3} = \frac{1}{v_3} - \frac{1}{u_3}$$

$$\Rightarrow \frac{1}{30} = \frac{1}{v_3} - \frac{1}{\infty}$$

$$\frac{1}{v_3} = \frac{1}{30}$$

$$v_3 = 30 \text{ cm}$$

The final image will form 30 cm from the third lens.

The distance of final image from object will be $30 + 10 + 5 + 30 = 75 \text{ cm}$

Thus, the distance of final image formed from object O is 75 cm.

Question 102

An object is placed at a distance of 12 cm from a convex lens. A convex mirror of focal length 15 cm is placed on other side of lens at 8 cm as shown in the figure. Image of object coincides with the object.

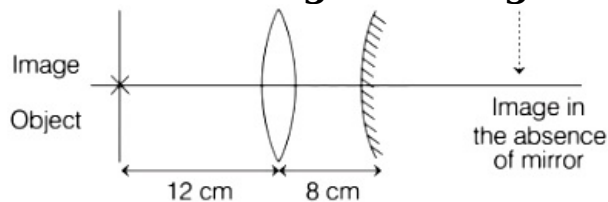

When the convex mirror is removed, a real and inverted image is formed at a position. The distance of the image from the object will be..... cm.

[26 Aug 2021 Shift 2]

Solution:

It is given that image coincides with the object. In the arrangement given, the image will only coincide with the object when the ray on mirror falls directly perpendicular on the surface of it.

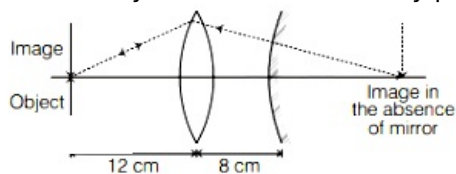

The light will converge at centre of curvature of mirror and due to that after removing the mirror the light will converge at same position.

The focal length of mirror, $f = 15 \text{ cm}$. So, radius of curvature of mirror, $2f = 30 \text{ cm}$

The image distance from the object after convex mirror is removed will be calculated as, $12 \text{ cm} + 8 \text{ cm} + 30 \text{ cm} = 50 \text{ cm}$.

Thus, the image will formed at a distance of 50 cm from object.



Question103

A glass tumbler having inner depth of 17.5 cm is kept on a table. A student starts pouring water ($\mu = \frac{4}{3}$) into it while looking at the surface of water from the above. When he feels that the tumbler is half filled, he stops pouring water. Up to what height, the tumbler is actually filled? [1 Sep 2021 Shift 2]

Options:

- A. 11.7 cm
- B. 10 cm
- C. 7.5 cm
- D. 8.75 cm

Answer: B

Solution:

Solution:

Let us draw the diagram of glass tumbler.

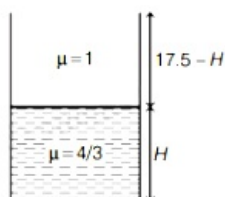

Consider the actual height of the tumbler be H .

The refractive index of the water, $\mu = \frac{4}{3}$

The refractive index of the air, $\mu = 1$

As we know that,

$$\mu_{\text{water}} = \frac{H_{\text{real}}}{H_{\text{apparent}}}$$

$$\frac{4}{3} = \frac{H}{H_{\text{apparent}}}$$

$$\Rightarrow H_{\text{apparent}} = \frac{3H}{4}$$

The height of air observed by observer = $17.5 - H$

According to the above figure,

$$\frac{3H}{4} = 17.5 - H$$

$$\Rightarrow H = 10.11 \text{ cm} \approx 10 \text{ cm}$$

The actual height of the water in tumbler is 10 cm.

Question104

An object is gradually moving away from the focal point of a concave mirror along the axis of the mirror. The graphical representation of the

**magnitude of linear magnification (m) versus distance of the object from the mirror (x) is correctly given by
(Graphs are drawn schematically and are not to scale)
[8 Jan. 2020 II]**

Options:

A.

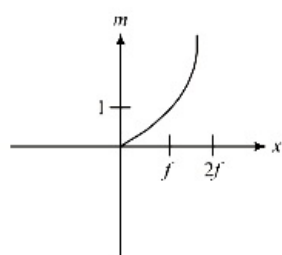

B.

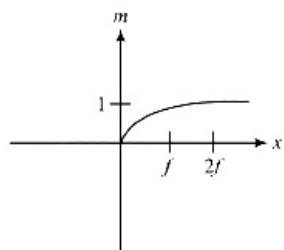

C.

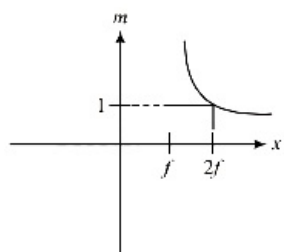

D.

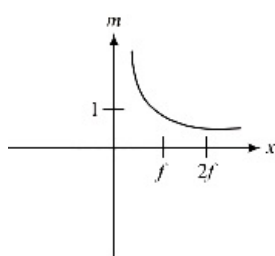

Answer: C

Solution:

Solution:

Using mirror formula, magnification is given by $m = \frac{f}{u - f} = \frac{-1}{1 - \frac{u}{f}}$

At focus magnification is ∞

And at $u = 2f$, magnification is 1 .

Hence graph (d) correctly depicts ' m ' versus distance of object ' x ' graph.

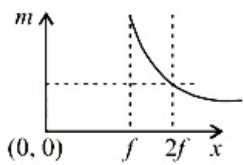

Question 105

A vessel of depth $2h$ is half filled with a liquid of refractive index $2\sqrt{2}$ and the upper half with another liquid of refractive index $\sqrt{2}$. The liquids are immiscible. The apparent depth of the inner surface of the bottom of vessel will be:

[9 Jan. 2020 I]

Options:

- A. $\frac{h}{\sqrt{2}}$
- B. $\frac{h}{2(\sqrt{2} + 1)}$
- C. $\frac{h}{3\sqrt{2}}$
- D. $\frac{3h\sqrt{2}}{4}$

Answer: D

Solution:

Apparent depth,
Real depth

$$h_{\text{app}} = 1 \left| \frac{h_1}{\mu_1} + \frac{h_2}{\mu_2} \right|$$

$$= \frac{h}{2\sqrt{2}} + \frac{h}{\sqrt{2}}$$

$$= \frac{h}{\sqrt{2}} \left(\frac{1}{2} + 1 \right) = \frac{3h}{2\sqrt{2}}$$

$$h_{\text{app}} = \frac{3h}{2\sqrt{2}} \times \frac{\sqrt{2}}{\sqrt{2}} = \frac{3h}{4} \times \sqrt{2}$$

$$h_{\text{app}} = \frac{3h}{4} \times \sqrt{2}$$

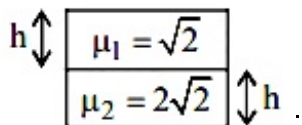

Question 106

There is a small source of light at some depth below the surface of water (refractive index = $\frac{4}{3}$) in a tank of large cross sectional surface area. Neglecting any reflection from the bottom and absorption by

water, percentage of light that emerges out of surface is (nearly):
[Use the fact that surface area of a spherical cap of height h and radius of curvature r is $2\pi rh$]

[9 Jan. 2020 II]

Options:

- A. 21%
- B. 34%
- C. 17%
- D. 50%

Answer: C

Solution:

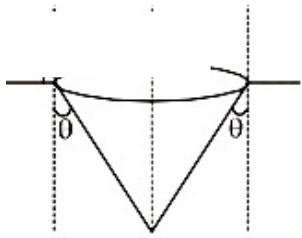

Given,

Refractive index, $\mu = \frac{4}{3}$

$$\frac{4}{3} \sin \theta = 1 \sin 90^\circ$$

$$\Rightarrow \sin \theta = \frac{3}{4}$$

$$\cos \theta = \frac{\sqrt{7}}{4}$$

$$\text{Solid angle, } \Omega = 2\pi(1 - \cos \theta) = 2\pi(1 - \sqrt{7} / 4)$$

Fraction of energy transmitted

$$= \frac{2\pi(1 - \cos \theta)}{4\pi} = \frac{1 - \sqrt{7} / 4}{2} = 0.17$$

Percentage of light emerges out of surface

$$= 0.17 \times 100 = 17\%$$

Question107

The critical angle of a medium for a specific wavelength, if the medium has relative permittivity 3 and relative permeability $\frac{4}{3}$ for this wavelength, will be:

[8 Jan. 2020 I]

Options:

- A. 15°
- B. 30°
- C. 45°
- D. 60°

Answer: B

Solution:

Solution:

Here, from question, relative permittivity

$$\epsilon_r = \frac{\epsilon}{\epsilon_0} = 3 \Rightarrow \epsilon = 3\epsilon_0$$

$$\text{Relative permeability } \mu_r = \frac{\mu}{\mu_0} = \frac{4}{3} \Rightarrow \mu = \frac{4}{3}\mu_0$$

$$\therefore \mu\epsilon = 4\mu_0\epsilon_0$$

$$\sqrt{\frac{\mu_0\epsilon_0}{\mu\epsilon}} = \frac{v}{c} = \frac{1}{2} \left(\because c = \frac{1}{\sqrt{\mu_0\epsilon_0}} \right)$$

$$n = \sqrt{\mu_r\epsilon_r} = \sqrt{\frac{4}{3} \times 3} = 2$$

$$\text{And } n = \frac{1}{\sin \theta_c}$$

$$\Rightarrow \sin \theta_c = \frac{1}{n} = \frac{1}{2}$$

$$\therefore \text{Critical angle, } \theta_c = 30^\circ$$

Question 108

A point object in air is in front of the curved surface of a plano-convex lens. The radius of curvature of the curved surface is 30 cm and the refractive index of the lens material is 1.5, then the focal length of the lens (in cm) is _____.

[NA 8 Jan. 2020 I]

Answer: 60

Solution:

Solution:

Given : $\mu = 1.5$; $R_{\text{curved}} = 30\text{cm}$

Using, Lens-maker formula

$$\frac{1}{f} = (\mu - 1) \left(\frac{1}{R_1} - \frac{1}{R_2} \right)$$

For plano-convex lens $R_1 \rightarrow \infty$ then $R_2 = -R$

$$\therefore f = \frac{R}{\mu - 1} = \frac{30}{1.5 - 1} = 60\text{cm}$$

Question 109

A thin lens made of glass (refractive index = 1.5) of focal length $f = 16$ cm is immersed in a liquid of refractive index 1.42. If its focal length in liquid is f_1 , then the ratio f_1 / f is closest to the integer:

[7 Jan. 2020 II]



Options:

- A. 1
- B. 9
- C. 5
- D. 17

Answer: B**Solution:****Solution:**

Using lens maker's formula

$$\frac{1}{f} = \left(\frac{\mu_g}{\mu_a} - 1 \right) \left[\frac{1}{R_1} - \frac{1}{R_2} \right]$$

Here, μ_g and μ_a are the refractive index of glass and air respectively

$$\Rightarrow \frac{1}{f} = (1.5 - 1) \left(\frac{1}{R_1} - \frac{1}{R_2} \right) \dots\dots(i)$$

When immersed in liquid

$$\frac{1}{f_1} = \left(\frac{\mu_g}{\mu_1} - 1 \right) \left(\frac{1}{R_1} - \frac{1}{R_2} \right)$$

[Here, μ_1 = refractive index of liquid]

$$\Rightarrow \frac{1}{f_1} = \left(\frac{1.5}{1.42} - 1 \right) \left(\frac{1}{R_1} - \frac{1}{R_2} \right) \dots\dots(ii)$$

Dividing (i) by(ii)

$$\Rightarrow \frac{f_1}{f} = \frac{(1.5 - 1)1.42}{0.08} = \frac{1.42}{0.16} = \frac{142}{16} \approx 9$$

Question110

The magnifying power of a telescope with tube length 60 cm is 5. What is the focal length of its eye piece?

[8 Jan. 2020 I]**Options:**

- A. 20 cm
- B. 40 cm
- C. 30 cm
- D. 10 cm

Answer: D**Solution:****Solution:**

For telescope

$$\text{Tube length (L)} = f_o + f_e = 60$$

$$\text{and magnification (m)} = \frac{f_o}{f_e} = 5 \Rightarrow f_o = 5f_e$$

$$\therefore f_o = 50\text{cm and } f_e = 10\text{cm}$$



Question111

If we need a magnification of 375 from a compound microscope of tube length 150 mm and an objective of focal length 5 mm, the focal length of the eye-piece, should be close to:

[7 Jan. 2020 I]

Options:

- A. 22 mm
- B. 12 mm
- C. 2 mm
- D. 33 mm

Answer: A

Solution:

Solution:

According question, $M = 375$

$L = 150\text{mm}$, $f_o = 5\text{mm}$ and $f_e = ?$

Using, magnification, $M \approx \frac{L}{f_o} \left(1 + \frac{D}{f_e} \right)$

$$\Rightarrow 375 = \frac{150}{5} \left(1 + \frac{250}{f_e} \right) \quad (\because D = 25\text{cm} = 250\text{mm})$$

$$\Rightarrow 12.5 = 1 + \frac{250}{f_e}$$

$$\Rightarrow f_e = \frac{250}{11.5} = 21.7 \approx 22\text{mm}$$

Question112

TOPIC 1 -Plane Mirror, Spherical Mirror and Reflection of Light When an object is kept at a distance of 30cm from a concave mirror, the image is formed at a distance of 10cm from the mirror. If the object is moved with a speed of 9 cms^{-1} , the speed (in cms^{-1}) with which image moves at that instant is _____.

[NA Sep. 03,2020 (II)]

Answer: 1

Solution:



Distance of object, $u = -30\text{cm}$

Distance of image, $v = 10\text{cm}$

$$\text{Magnification, } m = \frac{-v}{u} = \frac{-10}{-30} = \frac{1}{3}$$

$$\text{Speed of image} = m^2 \times \text{speed of object} = \frac{1}{9} \times 9 = 1\text{cms}^{-1}$$

Question 113

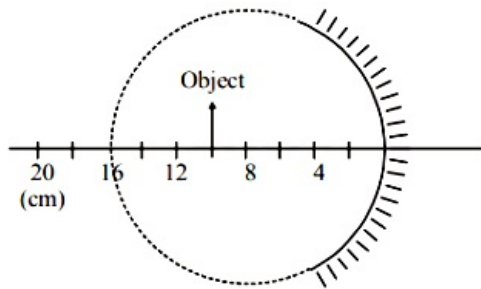

A spherical mirror is obtained as shown in the figure from a hollow glass sphere. If an object is positioned in front of the mirror, what will be the nature and magnification of the image of the object? (Figure drawn as schematic and not to scale)

[Sep. 02, 2020 (I)]

Options:

- A. Inverted, real and magnified
- B. Erect, virtual and magnified
- C. Erect, virtual and unmagnified
- D. Inverted, real and unmagnified

Answer: D

Solution:

Solution:

Object is placed beyond radius of curvature (R) of concave mirror hence image formed is real, inverted and diminished or unmagnified.

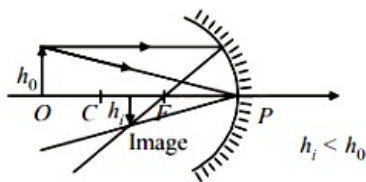

Question 114

TOPIC 2 - Refraction of Light at Plane Surface and Total Internal Reflection

An observer can see through a small hole on the side of a jar (radius 15 cm) at a point at height of 15 cm from the bottom (see figure). The hole

is at a height of 45 cm. When the jar is filled with a liquid up to a height of 30 cm the same observer can see the edge at the bottom of the jar. If the refractive index of the liquid is $N/100$, where N is an integer, the value of N is _____.

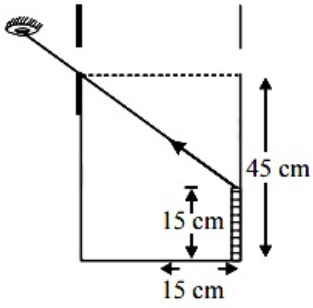

[NA Sep. 03, 2020 (I)]

Solution.

From figure, $\sin i = \frac{15}{\sqrt{15^2 + 30^2}}$ and $\sin r = \sin 45^\circ$

From Snell's law, $\mu \times \sin i = 1 \times \sin r$
 $\frac{15}{\sqrt{15^2 + 30^2}} = 1 \times \sin 45^\circ = \frac{1}{\sqrt{2}}$

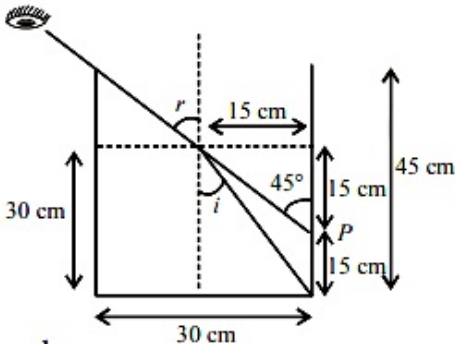

$$\therefore \mu = \frac{\frac{1}{\sqrt{2}}}{\frac{15}{\sqrt{1125}}} = 158 \times 10^{-2} = \frac{N}{100}$$

Hence, value of $N \approx 158$

Question 115

A light ray enters a solid glass sphere of refractive index $\mu = \sqrt{3}$ at an angle of incidence 60° . The ray is both reflected and refracted at the farther surface of the sphere. The angle (in degrees) between the reflected and refracted rays at this surface is _____.

[NA Sep. 02, 2020 (II)]

Answer: 90

Solution:

R is the reflected ray and QS is refracted ray. CQ is normal.

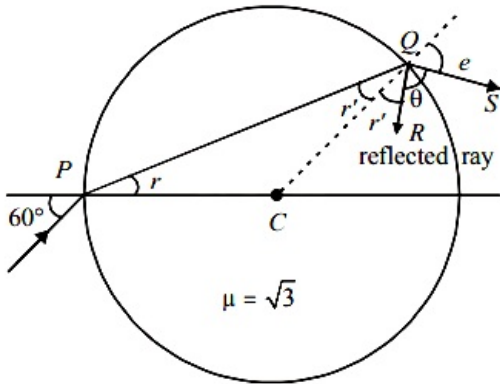

Apply Snell's law at P

$$1 \sin 60^\circ = \sqrt{3} \sin r$$

$$\Rightarrow \sin r = \frac{1}{2} \Rightarrow r = 30^\circ$$

From geometry, CP = CQ

$$\therefore r' = 30^\circ$$

Again apply Snell's law at Q,

$$\sqrt{3} \sin r' = 1 \sin e$$

$$\Rightarrow \frac{\sqrt{3}}{2} = \sin e \Rightarrow e = 60^\circ$$

From geometry

$$r' + \theta + e = 180^\circ \text{ (As angles lie on a straight line)}$$

$$\Rightarrow 30^\circ + \theta + 60^\circ = 180^\circ \Rightarrow \theta = 90^\circ$$

Question 116

TOPIC 3 - Refraction at Curved Surface Lenses and Power of Lens

A point like object is placed at a distance of 1 m in front of a convex lens of focal length 0.5 m. A plane mirror is placed at a distance of 2 m behind the lens. The position and nature of the final image formed by the system is :

[Sep. 06, 2020 (I)]

Options:

- A. 2.6 m from the mirror, real
- B. 1 m from the mirror, virtual
- C. 1 m from the mirror, real
- D. 2.6 m from the mirror, virtual

Answer: D

Solution:

Focal length of the convex lens, $f = 0.5\text{m}$

Object is at $2f$ so, image (I_1) will also be at $2f$.

i.e., I_2 will be 1m behind mirror.

Now I_2 will be object for lens.

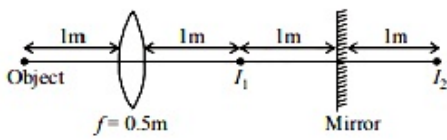

$$\therefore u = (-1) + (-1) + (-1) = -3\text{m}$$

Using lens formula, $\frac{1}{v} - \frac{1}{u} = \frac{1}{f}$

$$\frac{1}{v} = \frac{1}{f} + \frac{1}{u} = \frac{1}{+0.5} + \frac{1}{-3} \text{ or } v = \frac{3}{5} = 0.6\text{m}$$

Hence, distance of image from mirror
 $= 2 + 0.6 = 2.6\text{m}$ and real.

Question 117

A double convex lens has power P and same radii of curvature R of both the surfaces. The radius of curvature of a surface of a plano-convex lens made of the same material with power 1.5P is :

[Sep. 06, 2020 (II)]

Options:

A. 2R

B. $\frac{R}{2}$

C. $\frac{3R}{2}$

D. $\frac{R}{3}$

Answer: D

Solution:

Solution:

Given, using lens maker's formula

$$\frac{1}{f} = (k - 1) \left(\frac{1}{R_1} - \frac{1}{R_2} \right)$$

Here, $R_1 = R_2 = R$ (For double convex lens)

$$\therefore \frac{1}{f} = (\mu - 1) \left(\frac{1}{R} - \frac{1}{-R} \right)$$

$$\Rightarrow P = \frac{1}{f} = (\mu - 1) \frac{2}{R} \dots\dots(i)$$

For plano convex lens,

$$R_1 = R', R_2 = \infty$$

Using lens maker's formula again, we have

$$1.5P = (\mu - 1) \left(\frac{1}{R'} - \frac{1}{\infty} \right) \dots\dots(ii)$$

$$\Rightarrow \frac{3P}{2} = \frac{\mu - 1}{R'}$$

From (i) and (ii),

$$\frac{3}{2} = \frac{R'}{2R} \Rightarrow R' = \frac{R}{3}$$

Question 118

For a concave lens of focal length f, the relation between object and

image distances u and v , respectively, from its pole can best be represented by ($u = v$ is the reference line) :
[Sep. 05, 2020 (I)]

Options:

A.

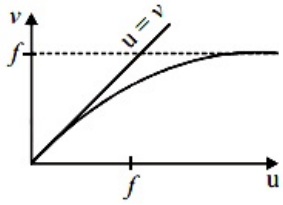

B.

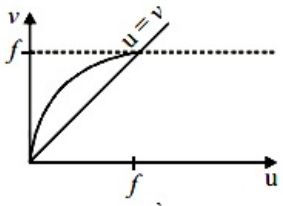

C.

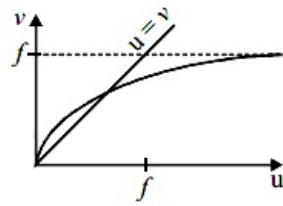

D.

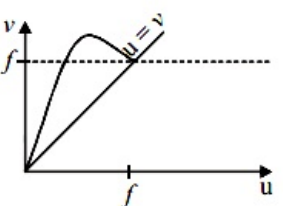

Answer: D

Solution:

Solution:

From lens formula,

$$\frac{1}{v} - \frac{1}{u} = \frac{1}{f} \Rightarrow v = \frac{uf}{u+f}$$

Case-I : If $v = u \Rightarrow f + u = f \Rightarrow u = 0$

Case-II : If $u = \infty$ then $v = f$.

Hence, correct u versus v graph, that satisfies this condition is (a).

Question119

The distance between an object and a screen is 100cm. A lens can produce real image of the object on the screen for two different

positions between the screen and the object. The distance between these two positions is 40cm. If the power of the lens is close to $\left(\frac{N}{100}\right) D$ where N is an integer, the value of N is _____.

[NA Sep. 04, 2020 (II)]

9

Given,

Distance between an object and screen, $D = 100$ cm

Distance between the two position of lens, $d = 40$ cm

Focal length of lens,

$$\frac{D^2 - d^2}{4(100)} = \frac{100^2 - 40^2}{4(100)} = \frac{(100 + 40)(100 - 40)}{4(100)} = 21\text{cm}$$

$$\text{Power, } P = \frac{1}{f} = \frac{100}{21} = \frac{N}{100}$$

$$\therefore N = 476.19$$

Question120

TOPIC 4 - Prism and Dispersion of Light

The surface of a metal is illuminated alternately with photons of energies $E_1 = 4\text{eV}$ and $E_2 = 2.5\text{eV}$ respectively. The ratio of maximum speeds of the photoelectrons emitted in the two cases is 2 . The work function of the metal in (eV) is _____.

[NA Sep. 05, 2020 (II)]

Answer: 2

Solution:

From the Einstein's photoelectric equation

Energy of photon = Kinetic energy of photoelectrons + Work function

\Rightarrow Kinetic energy = Energy of Photon – Work Function Let ϕ_0 be the work function of metal and v_1 and v_2 be the velocity of photoelectrons. Using Einstein's photoelectric equation we have

$$\frac{1}{2}mv_1^2 = 4 - \phi_0 \dots\dots(i)$$

$$\frac{1}{2}mv_2^2 = 2.5 - \phi_0 \dots\dots(ii)$$

$$\Rightarrow \frac{\frac{1}{2}mv_1^2}{\frac{1}{2}mv_2^2} = \frac{4 - \phi_0}{2.5 - \phi_0}$$

$$\Rightarrow (2)^2 = \frac{4 - \phi_0}{2.5 - \phi_0} \Rightarrow 10 - 4\phi_0 = 4 - \phi_0$$

$$\phi_0 = 2\text{eV}$$



Question121

. A compound microscope consists of an objective lens of focal length 1 cm and an eye piece of focal length 5 cm with a separation of 10 cm. The distance between an object and the objective lens, at which the strain on the eye is minimum is $\frac{n}{40}$ cm.

The value of n is _____.

[NA Sep. 05, 2020 (I)]

Answer: 50

Solution:

Given : Length of compound microscope, $L = 10\text{cm}$
Focal length of objective $f_0 = 1\text{cm}$ and of eye-piece,

$$f_e = 5\text{cm}$$

$$u_0 = f_e = 5\text{cm}$$

Final image formed at infinity (∞), $v_e = \infty$

$$v_0 = 10 - 5 = 5$$

Using lens formula, $\frac{1}{v} - \frac{1}{u} = \frac{1}{f}$

$$\frac{1}{v_0} - \frac{1}{u_0} = \frac{1}{f_0} \Rightarrow \frac{1}{5} - \frac{1}{u_0} = \frac{1}{1} \Rightarrow u_0 = -\frac{5}{4}\text{cm}$$

$$\text{or, } \frac{5}{4} = \frac{N}{40}$$

$$\therefore N = \frac{200}{4} = 50\text{cm}$$

Question122

In a compound microscope, the magnified virtual image is formed at a distance of 25 cm from the eye-piece. The focal length of its objective lens is 1 cm. If the magnification is 100 and the tube length of the microscope is 20 cm, then the focal length of the eye-piece lens (in cm) is _____.

[NA Sep. 04, 2020 (I)]

Answer: 4.48

Solution:



According to question, final image i.e., $v_2 = 25\text{cm}$,
 $f_o = 1\text{cm}$, magnification, $m = m_1 m_2 = 100$

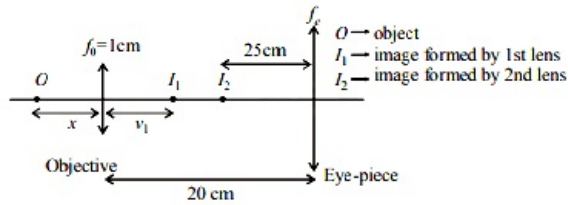

Using lens formula, For first lens or objective $= \frac{1}{v_1} - \frac{1}{-x} = \frac{1}{1} \Rightarrow v_1 = \frac{x}{x-1}$

Also magnification $|m_1| = \left| \frac{v_1}{u_1} \right| = \frac{1}{x-1}$

For 2nd lens or eye-piece, this is acting as object

$\therefore u_2 = -(20 - v_1) = -\left(20 - \frac{x}{x-1}\right)$ and $v_2 = -25\text{cm}$

Angular magnification $|m_A| = \left| \frac{D}{u_2} \right| = \frac{25}{|u_2|}$

Total magnification $m = m_1 m_A = 100$

$$\left(\frac{1}{x-1} \right) \left(\frac{25}{20 - \frac{x}{x-1}} \right) = 100$$

$$\Rightarrow \frac{25}{20(x-1) - x} = 100 \Rightarrow 1 = 80(x-1) - 4x$$

$$\Rightarrow 76x = 81 \Rightarrow x = \frac{81}{76}$$

$$\Rightarrow u_2 = -\left(20 - \frac{\frac{81}{76}}{\frac{81}{76} - 1}\right) = \frac{-19}{5}$$

Again using lens formula for eye-piece

$$\frac{1}{-25} - \frac{1}{-\frac{19}{5}} = \frac{1}{f_e} \Rightarrow f_e = \frac{25 \times 19}{106} \approx 4.48\text{cm}$$

Question 123

A point source of light, S is placed at a distance L in front of the centre of plane mirror of width d which is hanging vertically on a wall. A man walks in front of the mirror along a line parallel to the mirror, at a distance 2L as show below. The distance over which the man can see the image of the light source in the mirror is:

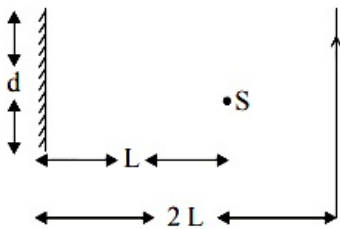

[12 Jan. 2019 I]

Options:

- A. d
- B. 2d
- C. 3d

D. $\frac{d}{2}$

Answer: C

Solution:

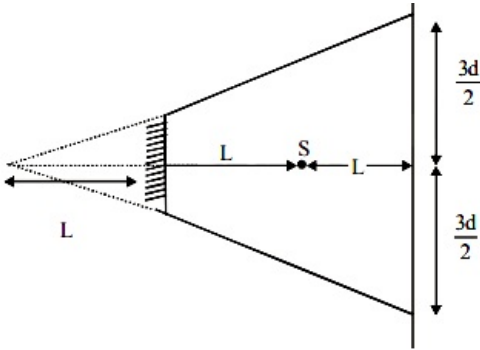

$$\text{Total distance} = \frac{3d}{2} + \frac{3d}{2} = 3d$$

Question124

Two plane mirrors are inclined to each other such that a ray of light incident on the first mirror (M_1) and parallel to the second mirror (M_2) is finally reflected from the second mirror (M_2) parallel to the first mirror (M_1). The angle between the two mirrors will be:

[9 Jan. 2019 II]

Options:

- A. 45°
- B. 60°
- C. 75°
- D. 90°

Answer: B

Solution:

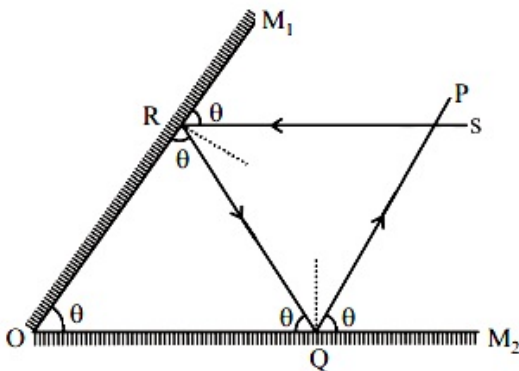

Let angle between the two mirrors be θ .
Ray $PQ \parallel$ mirror M_1 and $Rs \parallel$ mirror M_2

$\therefore M_1 R_s = \angle ORQ = \angle M_1 O M_2 = \theta$
 Similarly, $\angle M_2 Q P = \angle OQR = \angle M_2 O M_1 = \theta$
 In $\triangle ORQ$, $3\theta = 180^\circ \Rightarrow \theta = \frac{180^\circ}{3} = 60^\circ$

Question 125

A light wave is incident normally on a glass slab of refractive index 1.5. If 4% of light gets reflected and the amplitude of the electric field of the incident light is 30 V/m, then the amplitude of the electric field for the wave propagating in the glass medium will be:

[12 Jan. 2019 I]

Options:

- A. 30 V/m
- B. 10 V/m
- C. 24 V/m
- D. 6 V/m

Answer: C

Solution:

Solution:

As 4% of light gets reflected, so only $(100 - 4 = 96\%)$ of light comes after refraction so,

$$P_{\text{refracted}} = \frac{96}{100} P_I$$

$$\Rightarrow K_2 A_t^2 = \frac{96}{100} K_1 A_i^2$$

$$\Rightarrow r_2 A_t^2 = \frac{96}{100} r_1 A_i^2$$

$$\Rightarrow A_t^2 = \frac{96}{100} \times \frac{1}{3} \times (30)^2$$

$$A_t \sqrt{\frac{64}{100} \times (30)^2} = 24$$

Question 126

What is the position and nature of image formed by lens combination shown in figure? (f_1, f_2 are focal lengths)

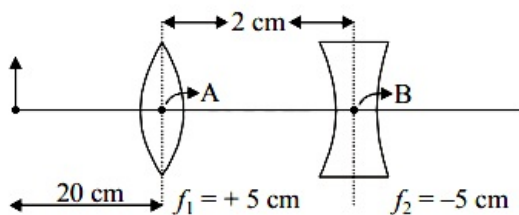

[12 Jan. 2019 I]

Options:

- A. 70 cm from point B at left; virtual
- B. 40 cm from point B at right; real
- C. $\frac{20}{3}$ cm from point B at right, real
- D. 70 cm from point B at right; real

Answer: D

Solution:

By lens's formula, $\frac{1}{v} - \frac{1}{u} = \frac{1}{f}$

For first lens, [$u_1 = -20$]

$$\frac{1}{v_1} - \frac{1}{-20} = \frac{1}{5} \Rightarrow v_1 = \frac{20}{3}$$

Image formed by first lens will behave as an object for second lens

$$\text{so, } u_2 = \frac{20}{3} - 2 = \frac{14}{3}$$

$$\frac{1}{v_2} - \frac{1}{\frac{14}{3}} = \frac{1}{-5} \Rightarrow v_2 = 70\text{cm}$$

Question127

Formation of real image using a biconvex lens is shown below :

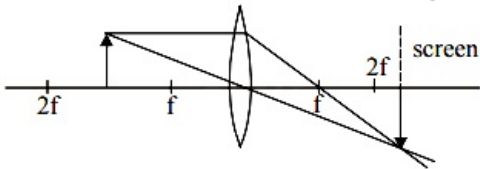

If the whole set up is immersed in water without disturbing the object and the screen positions, what will one observe on the screen ?

[12 Jan. 2019 II]

Options:

- A. Image disappears
- B. Magnified image
- C. Erect real image
- D. No change

Answer: A

Solution:

According to lens maker's formula,

$$\frac{1}{f} = (\mu_{rel} - 1) \left(\frac{1}{R_1} - \frac{1}{R_2} \right)$$

Focal length of lens will change due to change in refractive index μ_{rel} . So, image will be formed at new position. Hence image disappears

Question128

A plano-convex lens (focal length f_2 , refractive index μ_2 , radius of curvature R) fits exactly into a plano-concave lens (focal length f_1 , refractive index μ_1 , radius of curvature R). Their plane surfaces are parallel to each other. Then, the focal length of the combination will be :

[12 Jan. 2019 II]

Options:

A. $f_1 - f_2$

B. $\frac{R}{\mu_2 - \mu_1}$

C. $\frac{2f_1f_2}{f_1 + f_2}$

D. $f_1 + f_2$

Answer: B

Solution:

$$\frac{1}{f_2} = (\mu_2 - 1) \left(\frac{+1}{R} \right)$$

$$\frac{1}{f_1} = (\mu_1 - 1) \left(\frac{-1}{R} \right)$$

Now when combined the focal length is given by

$$\frac{1}{f} = \frac{1}{f_1} + \frac{1}{f_2}$$

$$= (\mu_1 - 1) \frac{(-1)}{R} + (\mu_2 - 1) \frac{+1}{R}$$

$$= \frac{1}{R} [\mu_2 - 1 - \mu_1 + 1]$$

$$= \frac{\mu_2 - \mu_1}{R}$$

$$\Rightarrow f = \frac{R}{\mu_2 - \mu_1}$$

Question129

An object is at a distance of 20 m from a convex lens of focal length 0.3 m. The lens forms an image of the object. If the object moves away from the lens at a speed of 5m/s, the speed and direction of the image will be :

[11 Jan. 2019 I]

Options:

- A. 2.26×10^{-3} m/s away from the lens
- B. 0.92×10^{-3} m/s away from the lens
- C. 3.22×10^{-3} m/s towards the lens
- D. 1.16×10^{-3} m/s towards the lens

Answer: D

Solution:

Solution:

By lens formula

$$\frac{1}{v} - \frac{1}{u} = \frac{1}{f}$$

$$\frac{1}{v} - \frac{1}{(-20)} = \frac{10}{3}$$

$$\frac{1}{v} = \frac{10}{3} - \frac{1}{20}$$

$$\frac{1}{v} = \frac{197}{60}; v = \frac{60}{197}$$

Magnification of lens (m) is given by

$$m = \left(\frac{v}{u} \right) = \left(\frac{60}{197} \right) \frac{1}{20}$$

velocity of image wrt. to lens is given by

$$v_{I/L} = m^2 v_{O/L}$$

direction of velocity of image is same as that of object

$$v_{O/L} = 5 \text{ m/s}$$

$$v_{I/L} = \left(\frac{60 \times 1}{197 \times 20} \right)^2$$

$$= 1.16 \times 10^{-3} \text{ m/s towards the lens}$$

Question 130

A plano convex lens of refractive index μ_1 and focal length f_1 is kept in contact with another plano concave lens of refractive index μ_2 and focal length f_2 . If the radius of curvature of their spherical faces is R each and $f_1 = 2f_2$, then μ_1 and μ_2 are related as:

[10 Jan. 2019 I]

Options:

- A. $\mu_1 + \mu_2 = 3$
- B. $2\mu_1 - \mu_2 = 1$
- C. $3\mu_2 - 2\mu_1 = 1$
- D. $2\mu_2 - \mu_1 = 1$

Answer: B

Solution:



From lens maker's formula,

$$\frac{1}{f} = (\mu - 1) \left(\frac{1}{R_1} - \frac{1}{R_2} \right)$$

$$\frac{1}{f_1} = (\mu_1 - 1) \left(\frac{1}{\infty} - \frac{1}{-R} \right) = \frac{1}{2f_2}$$

Similarly, for plano-concave lens

$$\frac{1}{f_2} = (\mu_2 - 1) \left(\frac{1}{-R} - \frac{1}{\infty} \right)$$

Dividing $\frac{1}{f_1}$ by $\frac{1}{f_2}$ we get,

$$\frac{(\mu_1 - 1)}{R} = \frac{(\mu_2 - 1)}{2R}$$

$$\text{or, } 2\mu_1 - \mu_2 = 1$$

Question131

The eye can be regarded as a single refracting surface. The radius of curvature of this surface is equal to that of cornea (7.8 mm). This surface separates two media of refractive indices 1 and 1.34. Calculate the distance from the refracting surface at which a parallel beam of light will come to focus.

[10 Jan. 2019 II]

Options:

- A. 1 cm
- B. 2 cm
- C. 4.0 cm
- D. 3.1 cm

Answer: D

Solution:

$$\frac{u}{v} - \frac{\mu_1}{u} = \frac{\mu_2 - \mu_1}{R}$$

$$R = 7.8\text{mm}$$

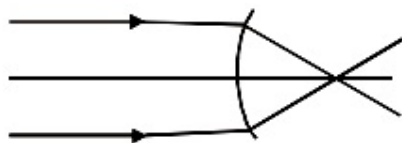

$$\mu_1 = 1, \mu_2 = 1.34$$

$$\Rightarrow \frac{1.34}{v} - \frac{1}{\infty} = \frac{1.34 - 1}{7.8} [\because u = \infty]$$

$$\therefore v = 30.7\text{mm} = 3.07\text{cm} \approx 3.1\text{cm}$$

Question132

A convex lens is put 10 cm from a light source and it makes a sharp image on a screen, kept 10 cm from the lens. Now a glass block

(refractive index 1.5) of 1.5 cm thickness is placed in contact with the light source. To get the sharp image again, the screen is shifted by a distance d. Then d is:

[9 Jan. 2019 I]

Options:

- A. 1.1 cm away from the lens
- B. 0
- C. 0.55 cm towards the lens
- D. 0.55 cm away from the lens

Answer: D

Solution:

Solution:

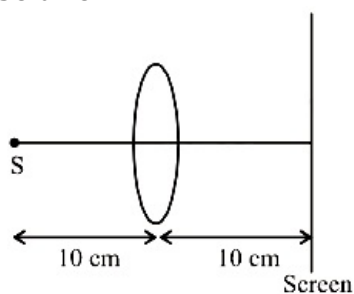

Using lens formula

$$\frac{1}{v} - \frac{1}{u} = \frac{1}{f} \Rightarrow \frac{1}{10} - \frac{1}{-10} = \frac{1}{f} \Rightarrow f = 5\text{cm}$$

Shift due to slab, $= t \left(1 - \frac{1}{\mu} \right)$ in the direction of incident ray

$$\text{or, } d = 1.5 \left(1 - \frac{2}{3} \right) = 0.5$$

Now, $u = -9.5$

$$\text{Again using lens formulas } \frac{1}{v} - \frac{1}{-9.5} = \frac{1}{5}$$

$$\Rightarrow \frac{1}{v} = \frac{1}{5} - \frac{2}{19} = \frac{9}{95}$$

$$\text{or, } v = \frac{95}{9} = 10.55\text{cm}$$

Thus, screen is shifted by a distance

$$d = 10.55 - 10 = 0.55\text{cm away from the lens.}$$

Question 133

The variation of refractive index of a crown glass thin prism with wavelength of the incident light is shown. Which of the following graphs is the correct one, if D_m is the angle of minimum deviation ?



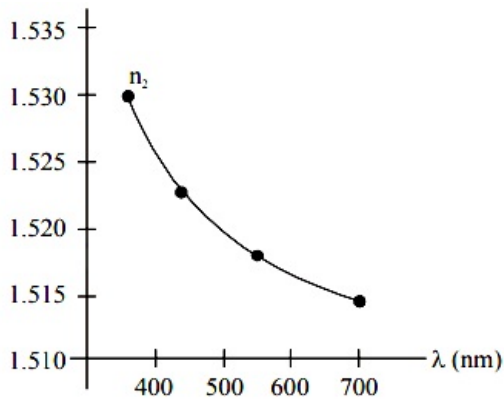

[11 Jan. 2019, I]

Options:

A.

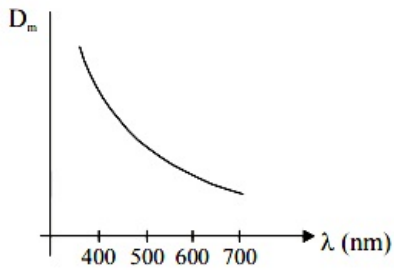

B.

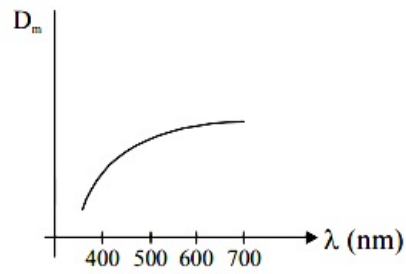

C.

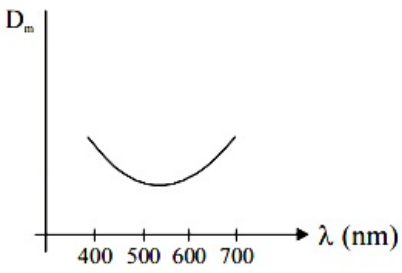

D.

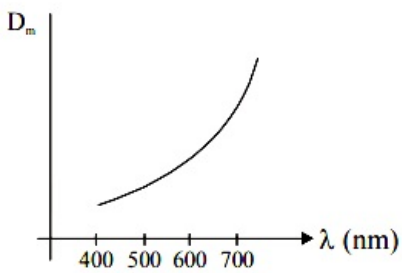

Answer: A

Solution:

Solution:

When angle of prism is small, then angle of deviation is given by $D_m = (\mu - 1)A$

So, if wavelength of incident light is increased, μ decreases and hence D_m decreases.

Question134

A monochromatic light is incident at a certain angle on an equilateral triangular prism and suffers minimum deviation. If the refractive index of the material of the prism is $\sqrt{3}$, then the angle of incidence is :
[11 Jan. 2019 II]

Options:

- A. 90°
- B. 30°
- C. 60°
- D. 45°

Answer: C

Solution:

Solution:

For minimum deviation:

$$r_1 = r_2 = \frac{A}{2} = 30^\circ$$

by Snell's law $\mu_1 \sin i = \mu_2 \sin r$

$$1 \times \sin i = \sqrt{3} \times \frac{1}{2} = \frac{\sqrt{3}}{2} \Rightarrow i = 60^\circ$$

Question135

A concave mirror for face viewing has focal length of 0.4 m. The distance at which you hold the mirror from your face in order to see your image upright with a magnification of 5 is:
[9 April 2019 I]

Options:

- A. 0.24 m
- B. 1.60 m
- C. 0.32 m
- D. 0.16 m

Answer: C



Solution:

Solution:

$$+5 = -\frac{v}{u} \Rightarrow v = -5u$$

$$\text{Using } \frac{1}{v} + \frac{1}{u} = \frac{1}{f}$$

$$\text{or } \frac{1}{-5u} + \frac{1}{u} = \frac{1}{0.4}$$

$$\therefore u = 0.32\text{m}$$

Question 136

A concave mirror has radius of curvature of 40 cm. It is at the bottom of a glass that has water filled up to 5 cm (see figure). If a small particle is floating on the surface of water, its image as seen, from directly above the glass, is at a distance d from the surface of water. The value of d is close to :

(Refractive index of water = 1.33)

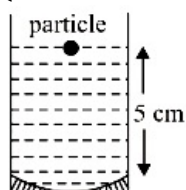

[12 Apr. 2019 I]

Options:

- A. 6.7 cm
- B. 13.4 cm
- C. 8.8 cm
- D. 11.7 cm

Answer: C

Solution:

Solution:

If v is the distance of image formed by mirror, then

$$\frac{1}{v} + \frac{1}{u} = \frac{1}{f}$$

$$\text{or } \frac{1}{v} + \frac{1}{-5} = \frac{1}{-20}$$

$$\therefore v = \frac{20}{3}\text{cm}$$

Distance of this image from water surface

$$= \frac{20}{3} + 5 = \frac{35}{3}\text{cm}$$

$$\text{Using, } \frac{RD}{AD} = \mu$$

$$\therefore AD = d = \frac{RD}{\mu} = \frac{(35/3)}{1.33} = 8.8\text{cm}$$

Question137

A transparent cube of side d , made of a material of refractive index μ_2 , is immersed in a liquid of refractive index μ_1 ($\mu_1 < \mu_2$). A ray is incident on the face AB at an angle θ (shown in the figure). Total internal reflection takes place at point E on the face BC.

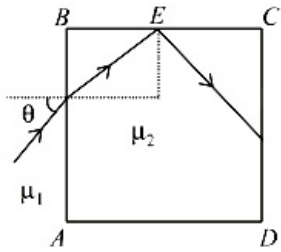

Then θ must satisfy :
[12 Apr. 2019 II]

Options:

- A. $\theta < \sin^{-1} \frac{\mu_1}{\mu_2}$
- B. $\theta > \sin^{-1} \sqrt{\frac{\mu_2^2}{\mu_1^2} - 1}$
- C. $\theta < \sin^{-1} \sqrt{\frac{\mu_2^2}{\mu_1^2} - 1}$
- D. $\theta > \sin^{-1} \frac{\mu_1}{\mu_2}$

Answer: C

Solution:

Solution:

$$\text{Using, } \sin \theta_{\max} = \mu_1 \sqrt{\mu_2^2 - \mu_1^2} = \sqrt{\frac{\mu_2^2}{\mu_1^2} - 1}$$

$$\text{or } \theta_{\max} = \sin^{-1} \left(\sqrt{\frac{\mu_2^2}{\mu_1^2} - 1} \right)$$

$$\text{For T}_1\text{R, } \theta < \sin^{-1} \left(\sqrt{\frac{\mu_2^2}{\mu_1^2} - 1} \right)$$

Question138

A ray of light AO in vacuum is incident on a glass slab at angle 60° and refracted at angle 30° along OB as shown in the figure. The optical path length of light ray from A to B is :

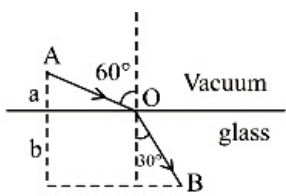

[10 Apr. 2019 I]

Options:

A. $\frac{2\sqrt{3}}{a} + 2b$

B. $2a\frac{2b}{3}$

C. $2a + \frac{2b}{\sqrt{3}}$

D. $2a + 2b$

Answer: D

Solution:

Solution:

From the given figure

As $\sin 60^\circ = \mu \sin 30^\circ$

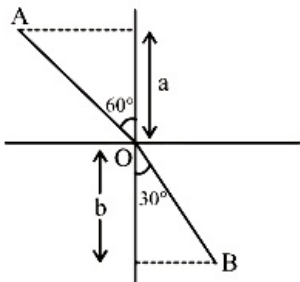

$\Rightarrow \mu = \frac{\sin 60^\circ}{\sin 30^\circ} = \sqrt{3}$

$\frac{a}{AO} = \cos 60^\circ \Rightarrow AO = 2a$

$\frac{b}{BO} = \cos 30^\circ \Rightarrow BO = \frac{2b}{\sqrt{3}}$

Optical path length = $AO + \mu BO$

$= 2a + (\sqrt{3})\frac{2b}{\sqrt{3}} = 2a + 2b$

Question 139

In figure, the optical fiber is $l = 2\text{m}$ long and has a diameter of $d = 20\mu\text{m}$. If a ray of light is incident on one end of the fiber at angle $\theta_1 = 40^\circ$, the number of reflections it makes before emerging from the other end is close to :
(refractive index of fiber is 1.31 and $\sin 40^\circ = 0.64$)

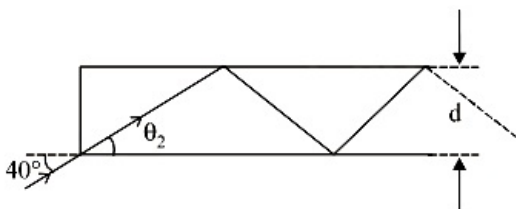

[8 April 2019 I]

Options:

- A. 55000
- B. 66000
- C. 45000
- D. 57000

Answer: D

Solution:

Solution:

Using Snell's law of refraction,

$$1 \times \sin 40^\circ = 1.31 \sin \theta$$

$$\Rightarrow \sin \theta = \frac{0.64}{1.31} = 0.49 \approx 0.5$$

$$\Rightarrow \theta = 30^\circ$$

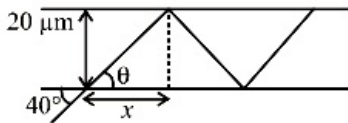

$$x = 20\mu\text{m} \times \cot \theta$$

$$\therefore \text{Number of reflections} = \frac{2}{20 \times 10^{-6} \times \cot \theta}$$

$$= \frac{2 \times 10^6}{20 \times \sqrt{3}} = 57735 \approx 57000$$

Question140

One plano-convex and one plano-concave lens of same radius of curvature 'R' but of different materials are joined side by side as shown in the figure. If the refractive index of the material of 1 is μ_1 and that of 2 is μ_2 , then the focal length of the combination is :

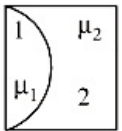

[10 Apr. 2019 I]

Options:

- A. $\frac{R}{\mu_1 - \mu_2}$
- B. $\frac{2R}{\mu_1 - \mu_2}$
- C. $\frac{2R}{2(\mu_1 - \mu_2)}$
- D. $\frac{R}{2 - (\mu_1 - \mu_2)}$



Answer: A

Solution:

Solution:

Focal length of plano-convex lens-

$$\frac{1}{f_1} = (\mu_1 - 1) \left(\frac{1}{\infty} - \frac{1}{-R} \right) = \frac{\mu_1 - 1}{R}$$

$$\Rightarrow f_1 = \frac{R}{(\mu_1 - 1)}$$

Focal length of plano-concave lens -

$$\frac{1}{f_2} = (\mu_2 - 1) \left(\frac{1}{-R} - \frac{1}{\infty} \right) = \frac{\mu_2 - 1}{-R}$$

$$\Rightarrow f_2 = \frac{-R}{(\mu_2 - 1)}$$

For the combination of two lens-

$$\frac{1}{f_{eq}} = \frac{1}{f_1} + \frac{1}{f_2} = \frac{\mu_1 - 1}{R} - \frac{\mu_2 - 1}{R}$$

$$= \frac{\mu_1 - \mu_2}{R}$$

$$\Rightarrow f_{eq} = \frac{R}{\mu_1 - \mu_2}$$

Question 141

The graph shows how the magnification m produced by a thin lens varies with image distance v . What is the focal length of the lens used ?

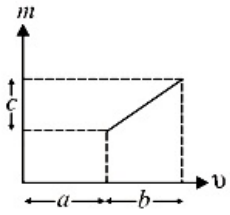

[10 Apr. 2019 II]

Options:

A. $\frac{b^2}{ac}$

B. $\frac{b^2c}{a}$

C. $\frac{a}{c}$

D. $\frac{b}{c}$

Answer: D

Solution:

Solution:

From the equation of line
 $m = k_1v + k_2$ ($\because y = mx + c$)

$$\Rightarrow \frac{v}{u} = k_1v + k_2 \left(\because m = \frac{v}{u} \right)$$

$$\Rightarrow \frac{1}{u} = k_1 + \frac{k_2}{v} \text{ (Dividing both sides by } v \text{)}$$

$$\Rightarrow \frac{k_2}{v} - \frac{1}{u} = k_1$$

Comparing with lens formula $\frac{1}{v} - \frac{1}{u} = \frac{1}{f}$, we get

$$k_1 = \frac{1}{-f} \text{ and } k_2 = 1$$

$$\therefore f = \frac{1}{\text{slope of } m - v \text{ graph}} = -\frac{b}{c}$$

Question142

A convex lens of focal length 20cm produces images of the same magnification 2 when an object is kept at two distances x_1 and

x_2 ($x_1 > x_2$) from the lens. The ratio of x_1 and x_2 is:

[9 Apr. 2019 II]

Options:

A. 2: 1

B. 3: 1

C. 5: 3

D. 4: 3

Answer: B

Solution:

Solution:

Using, $M = \frac{v}{u}$

$$\text{or } -2 = \frac{v_1}{x_1} \Rightarrow v_1 = -2x_1$$

We have $\frac{1}{v} - \frac{1}{u} = \frac{1}{f}$

$$\text{or } \frac{1}{-2x_1} - \frac{1}{x_1} = \frac{1}{20}$$

$$x_1 = 30\text{cm}$$

$$\text{And } \frac{1}{2x_2} - \frac{1}{x_2} = \frac{1}{20}$$

$$\text{or } x_2 = -10\text{cm}$$

$$\text{So, } \frac{x_1}{x_2} = \frac{30}{10} = 3$$

Question143

A thin convex lens L (refractive index = 1.5) is placed on a plane mirror M . When a pin is placed at A, such that OA = 18cm, its real inverted image is formed at A itself, as shown in figure. When a liquid of refractive index μ_l is put between the lens and the mirror, the pin has to

be moved to A', such that OA' = 27cm, to get its inverted real image at A' itself. The value of μ_1 will be:

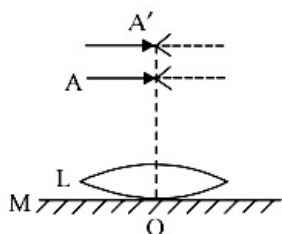

[9 Apr. 2019 II]

Options:

- A. $\frac{4}{3}$
- B. $\frac{3}{2}$
- C. $\sqrt{3}$
- D. $\sqrt{2}$

Answer: A

Solution:

Solution:

$$\frac{1}{f_1} = \frac{2}{f_1}$$

Here $2f_1 = 18\text{cm}$ or $f_1 = 9\text{cm}$

$$\text{So, } \frac{1}{9} = \frac{2}{f_1} \text{ or } f_1 = 18\text{cm}$$

$$\text{Using, } \frac{1}{f_1} = (\mu - 1) \left(\frac{2}{R} \right)$$

$$\text{or } \frac{1}{18} = (1.5 - 1) \left(\frac{2}{R} \right)$$

$$\therefore R = 18\text{cm}$$

when liquid is put between, then

$$\frac{1}{f_2} = \frac{2}{f_1} + \frac{2}{f}$$

$$\text{or } \frac{1}{(27/2)} = \frac{2}{18} + \frac{2}{f}$$

$$\text{or } f = -54\text{cm}$$

$$\text{Now } -\frac{1}{54} = (\mu_1 - 1) \times \frac{1}{R}$$

$$= (\mu_1 - 1) \times \left(\frac{1}{-18} \right)$$

$$\therefore \mu_1 = \frac{1}{3} + 1 = \frac{4}{3}$$

Question144

An upright object is placed at a distance of 40 cm in front of a convergent lens of focal length 20 cm. A convergent mirror of focal length 10 cm is placed at a distance of 60 cm on the other side of the lens. The position and size of the final image will be :

[8 April 2019 I]

Options:

- A. 20 cm from the convergent mirror, same size as the object
- B. 40 cm from the convergent mirror, same size as the object
- C. 40 cm from the convergent lens, twice the size of the object
- D. (Bouns)

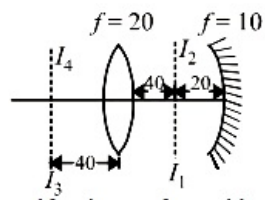
Answer: D**Solution:****Solution:**

$$v_1 = \frac{40 \times 20}{(40 - 20)} = 40\text{cm}$$

$$u_2 = 60 - 40 = 20\text{cm}$$

$$\therefore v_2 = \frac{20 \times 10}{(20 - 10)} = 20\text{cm}$$

\therefore Image traces back to object itself as image formed by lens is a centre of curvature of mirror.

Question145

A convex lens (of focal length 20 cm) and a concave mirror, having their principal axes along the same lines, are kept 80 cm apart from each other. The concave mirror is to the right of the convex lens. When an object is kept at a distance of 30 cm to the left of the convex lens, its image remains at the same position even if the concave mirror is removed. The maximum distance of the object for which this concave mirror, by itself would produce a virtual image would be :

[8 Apr. 2019 II]

Options:

- A. 30 cm
- B. 25 cm
- C. 10 cm
- D. 20 cm

Answer: C**Solution:****Solution:**

For lens

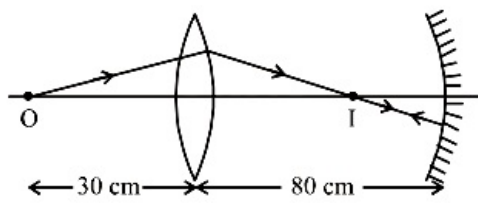

$$\frac{1}{v} - \frac{1}{u} = \frac{1}{f}$$

$$\text{or } \frac{1}{v} - \frac{1}{-30} = \frac{1}{20}$$

$$\therefore v = +60\text{cm}$$

According to the condition, image formed by lens should be the centre of curvature of the mirror, and so $2f' = 20$ or $f' = 10\text{cm}$

Question146

A particle is oscillating on the X-axis with an amplitude 2cm about the point $x_0 = 10\text{cm}$ with a frequency ω . A concave mirror of focal length 5cm is placed at the origin (see figure) Identify the correct statements:

- (A) The image executes periodic motion
- (B) The image executes non-periodic motion
- (C) The turning points of the image are asymmetric w.r.t the image of the point at $x = 10\text{cm}$
- (D) The distance between the turning points of the oscillation of the image is $\frac{100}{21} = 0$

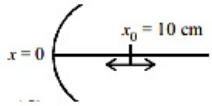

[Online April 15, 2018]

Options:

- A. (B), (D)
- B. (B), (C)
- C. (A), (C), (D)
- D. (A), (D)

Answer: C

Solution:

Object is at 8cm

$$\text{Image } v_1 = \frac{f \times u}{u - f} = \frac{5 \times 8}{8 - 5} = -\frac{40}{3}\text{cm}$$

When object is at 12cm

$$\text{Image } v_2 = \frac{f \times u}{u - f} = \frac{5 \times 12}{12 - 5} = -\frac{60}{7}\text{cm}$$

$$\text{Separation} = |v_1 - v_2| = \left| \frac{40}{3} - \frac{60}{7} \right| = \frac{100}{21}\text{cm}$$

So A, C and D are correct statements.

Question147

A planoconvex lens becomes an optical system of 28 cm focal length when its plane surface is silvered and illuminated from left to right as shown in Fig-A. If the same lens is instead silvered on the curved surface and illuminated from other side as in Fig. B, it acts like an optical system of focal length 10 cm. The refractive index of the material of lens is:

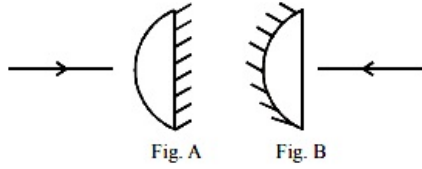

Fig. A

Fig. B

[Online April 15, 2018]

Options:

- A. 1.50
- B. 1.55
- C. 1.75
- D. 1

Answer: B

Solution:

Case 1

$$\left(\cup + \parallel \right) \equiv \left(\cup \right)$$

$$\frac{1}{f_1} = \left(\frac{\mu - 1}{R} \right) \quad f = -28$$

$$P = 2P_1 + P_2 \Rightarrow \frac{1}{28} = 2 \left(\frac{\mu - 1}{R} \right) \quad \left(\because \text{Power, } P = \frac{1}{f} \text{ \& } f_{\text{plane mirror}} = \infty \right)$$

Case-2

$$\left(\cup \right) + \left(\cup \right) \equiv \left(\cup \right)$$

$$\frac{1}{f_1} = \left(\frac{\mu - 1}{R} \right) \quad f_2 = -\frac{R}{2} \quad f = -10 \text{ cm}$$

$$P = 2P_1 + P_2 \Rightarrow \frac{1}{10} = 2 \left(\frac{\mu - 1}{2} \right) + \frac{2}{R}$$

$$\text{or, } \frac{1}{10} = \frac{1}{28} + \frac{2}{R} \Rightarrow \frac{2}{R} = \frac{1}{10} - \frac{1}{28} = \frac{18}{280}$$

$$\text{or, } R = \frac{280}{9} \text{ cm}$$

$$\text{or, } \frac{1}{28} = 2 \left(\frac{\mu - 1}{280} \right) \Rightarrow \mu - 1 = \frac{5}{9}$$

$$\therefore \mu = 1 + \frac{5}{9} = \frac{14}{9} = 1.55$$

Question148

A convergent doublet of separated lenses, corrected for spherical aberration, has resultant focal length of 10cm. The separation between the two lenses is 2cm. The focal lengths of the component lenses [Online April 15, 2018]

Options:

- A. 18cm, 20cm
- B. 10cm, 12cm
- C. 12cm, 14cm
- D. 16cm, 18cm

Answer: A

Solution:

Solution:

For minimum spherical aberration separation,

$$d = f_1 - f_2 = 2\text{cm}$$

Resultant focal length = $F = 10\text{cm}$

Using $\frac{1}{F} = \frac{1}{f_1} + \frac{1}{f_2} - \frac{d}{f_1 f_2}$ and solving, we get f_1, f_2 18 cm and 20cm respectively.

Question149

A ray of light is incident at an angle of 60° on one face of a prism of angle 30° . The emergent ray of light makes an angle of 30° with incident ray. The angle made by the emergent ray with second face of prism will be: [Online April 16, 2018]

Options:

- A. 30°
- B. 90°
- C. 0°
- D. 45°

Answer: C

Solution:

Solution:



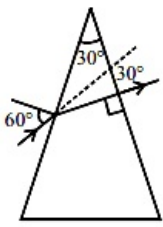

Angle of prism, $A = 30^\circ$, $i = 60^\circ$,
angle of deviation, $\delta = 30^\circ$

Using formula, $\delta = i + e - A$

$$\Rightarrow e = \delta + A - i$$

$$= 30^\circ + 30^\circ - 60^\circ = 0^\circ$$

\therefore Emergent ray will be perpendicular to the face

So it will make angle 90° with the face through which it emerges.

Question 150

Let the refractive index of a denser medium with respect to a rarer medium be n_{12} and its critical angle be θ_C . At an angle of incidence A when light is travelling from denser medium to rarer medium, a part of the light is reflected and the rest is refracted and the angle between reflected and refracted rays is 90° . Angle A is given by:

[Online April 8, 2017]

Options:

A. $\frac{1}{\cos^{-1}(\sin \theta_C)}$

B. $\frac{1}{\tan^{-1}(\sin \theta_C)}$

C. $\cos^{-1}(\sin \theta_C)$

D. $\tan^{-1}(\sin \theta_C)$

Answer: D

Solution:

Solution:

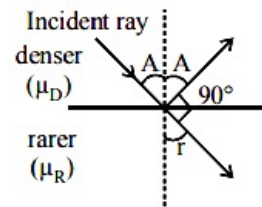

From Snell's law, $\frac{\mu_R}{\mu_D} = \frac{\sin i}{\sin r}$

$\therefore \angle i = A$ and $\angle r = (90^\circ - A)$

We also know that, $\sin \theta_C = \frac{\mu_R}{\mu_D}$

From eqⁿ(i), $\sin \theta_C = \frac{\sin A}{\sin(90^\circ - A)}$

$$\sin \theta_C = \frac{\sin A}{\cos A}$$

$$\sin \theta_C = \tan A$$

$$\text{or } A = \tan^{-1}(\sin \theta_c)$$

Question151

In an experiment a convex lens of focal length 15 cm is placed coaxially on an optical bench in front of a convex mirror at a distance of 5 cm from it. It is found that an object and its image coincide, if the object is placed at a distance of 20 cm from the lens. The focal length of the convex mirror is :

[Online April 9, 2017]

Options:

- A. 27.5 cm
- B. 20.0 cm
- C. 25.0 cm
- D. 30.5 c

Answer: A

Solution:

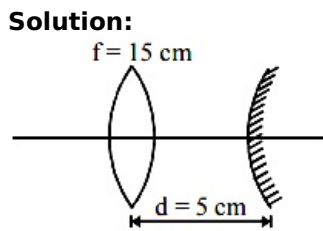

Given, focal length of lens (f) = 15 cm
object is placed at a distance (u) = - 20 cm

By lens formula,

$$\frac{1}{f} = \frac{1}{v} - \frac{1}{u}$$

$$\frac{1}{v} = \frac{1}{f} + \frac{1}{u} = \frac{1}{15} - \frac{1}{20}$$

$$\frac{1}{v} = \frac{4 - 3}{60}$$

$$v = 60 \text{ cm}$$

The image I gets formed at 60 cm to the right of the lens and it will be inverted.

The rays from the image (I) formed further falls on the convex mirror forms another image. This image should be formed in such a way that it coincides with the object at the same point due to reflection taking place by the convex mirror.

Distance between lens and mirror will be

$$d = \text{image distance } (v) - \text{radius of curvature of convex mirror}$$

$$5 = 60 - 2f$$

$$2f = 60 - 5$$

$$f = \frac{55}{2} = 27.5 \text{ cm (convex mirror)}$$

Question152

A hemispherical glass body of radius 10 cm and refractive index 1.5 is silvered on its curved surface. A small air bubble is 6 cm below the flat



surface inside it along the axis. The position of the image of the air bubble made by the mirror is seen :

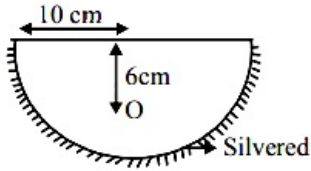

[Online April 10, 2016]

Options:

- A. 14 cm below flat surface
- B. 20 cm below flat surface
- C. 16 cm below flat surface
- D. 30 cm below flat surface

Answer: B

Solution:

Solution:

Given, radius of hemispherical glass $R = 10\text{cm}$

$$\therefore \text{Focal length } f = \frac{10}{2} = -5\text{cm}$$

$$u = (10 - 6) = -4\text{cm}$$

By using mirror formula,

$$\frac{1}{v} + \frac{1}{u} = \frac{1}{f} \Rightarrow \frac{1}{v} + \frac{1}{-4} = \frac{1}{-5} \Rightarrow v = 20\text{cm}$$

$$\text{Apparent height, } h_a = h_r \frac{\mu_1}{\mu_2} = 30 \times \frac{1}{1.5} = 20\text{cm below flat surface.}$$

Question153

A convex lens, of focal length 30 cm, a concave lens of focal length 120 cm, and a plane mirror are arranged as shown. For an object kept at a distance of 60 cm from the convex lens, the final image, formed by the combination, is a real image, at a distance of

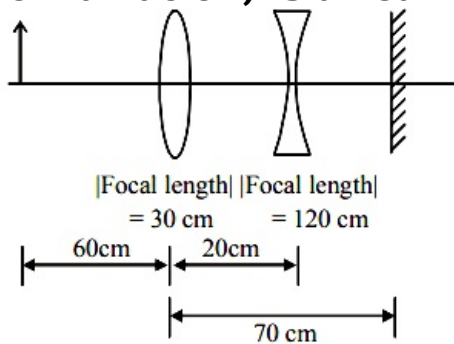

[Online April 9, 2016]

Options:

- A. 60 cm from the convex lens
- B. 60 cm from the concave lens

C. 70 cm from the convex lens

D. 70 cm from the concave lens

Answer: A

Solution:

Solution:

Len's formula is given by

$$\frac{1}{f} = \frac{1}{v} - \frac{1}{u}$$

For convex lens,

$$\frac{1}{30} = \frac{1}{v} + \frac{1}{60} \Rightarrow \frac{1}{60} = \frac{1}{v}$$

Similarly for concave lens

$$\frac{1}{-120} = \frac{1}{v} - \frac{1}{40} \Rightarrow \frac{1}{v} = \frac{1}{60}$$

Virtual object 10cm behind plane mirror.

Hence real image 10cm in front of mirror or, 60cm from convex lens.

Question 154

To find the focal length of a convex mirror, a student records the following data :

Object Pin	Convex Lens	Convex Mirror	Image Pin
22.2cm	32.2cm	45.8cm	71.2cm

The focal length of the convex lens is f_1 and that of mirror is f_2 . Then taking index correction to be negligibly small, f_1 and f_2 are close to :

[Online April 9, 2016]

Options:

A. $f_1 = 7.8\text{cm}, f_2 = 12.7\text{cm}$

B. $f_1 = 12.7\text{cm}, f_2 = 7.8\text{cm}$

C. $f_1 = 15.6\text{cm}, f_2 = 25.4\text{cm}$

D. $f_1 = 7.8\text{cm}, f_2 = 25.4\text{cm}$

Answer: A

Solution:

Solution:

Taking $f_2 = 12.07$

Using Mirror's formula

$$\frac{1}{f} = \frac{1}{v} + \frac{1}{u}$$

$$\Rightarrow \frac{1}{12.7} = \frac{1}{25.4} + \frac{1}{u} \Rightarrow \frac{1}{12.7} - \frac{1}{25.4} = \frac{1}{u}$$

$$u = 25.4 = v'$$

Now using Len's formula

$$\frac{1}{f} = \frac{1}{v} - \frac{1}{u} \Rightarrow \frac{1}{f_1} = \frac{1}{25.4 + 13.6} + \frac{1}{10}$$

$$\Rightarrow \frac{1}{f_1} = \frac{1}{39} + \frac{1}{10} \Rightarrow f_1 = \frac{390}{49} = 7.96$$

The closest answers is (a) as option (c) and (d) are not possible.

Question155

In an experiment for determination of refractive index of glass of a prism by $i - \delta$, plot it was found that a ray incident at angle 35° , suffers a deviation of 40° and that it emerges at angle 79° . In that case which of the following is closest to the maximum possible value of the refractive index?

[2016]

Options:

- A. 1.7
- B. 1.8
- C. 1.5
- D. 1.6

Answer: C

Solution:

Solution:

We know that $i + e - A = \delta$

$$35^\circ + 79^\circ - A = 40^\circ \therefore A = 74^\circ$$

$$\text{But } \mu = \frac{\sin\left(\frac{A + \delta_m}{2}\right)}{\sin\frac{A}{2}} = \frac{\sin\left(\frac{74 + \delta_m}{2}\right)}{\sin\frac{74}{2}}$$

$$= \frac{5}{3} \sin\left(37^\circ + \frac{\delta_m}{2}\right)$$

μ_{\max} can be $\frac{5}{3}$. That is μ_{\max} is less than $\frac{5}{3} = 1.67$

But δ_m will be less than 40° so

$$\mu < \frac{5}{3} \sin 57^\circ < \frac{5}{3} \sin 60^\circ \Rightarrow \mu = 1.5$$

Question156

An observer looks at a distant tree of height 10 m with a telescope of magnifying power of 20. To the observer the tree appears :

[2016]

Options:

- A. 20 times taller
- B. 20 times nearer



- C. 10 times taller
- D. 10 times nearer

Answer: B

Solution:

Solution:

A telescope magnifies by making the object appearing closer

Question157

**To determine refractive index of glass slab using a travelling microscope, minimum number of readings required are :
[Online April 10, 2016]**

Options:

- A. Two
- B. Four
- C. Three
- D. Five

Answer: C

Solution:

Solution:

Reading one \Rightarrow without slab

Reading two \Rightarrow with slab

Reading three \Rightarrow with saw dust

Minimum three readings are required to determine refractive index of glass slab using a travelling microscope.

Question158

**You are asked to design a shaving mirror assuming that a person keeps it 10 cm from his face and views the magnified image of the face at the closest comfortable distance of 25 cm. The radius of curvature of the mirror would then be :
[Online April 10, 2015]**

Options:

- A. 60 cm
- B. -24 cm
- C. - 60 cm

D. 24 cm

Answer: C

Solution:

Solution:

Convex mirror is used as a shaving mirror.

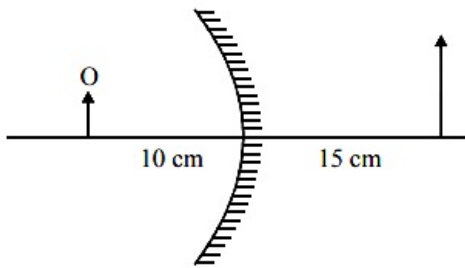

From question : $v = 15\text{cm}$, $u = -10\text{cm}$

Radius of curvature, $R = 2f = ?$

Using mirror formula, $\frac{1}{v} + \frac{1}{u} = \frac{1}{f}$

$$\frac{1}{15} + \frac{1}{(-10)} = \frac{1}{f} \Rightarrow f = -30\text{cm}$$

Therefore radius of curvature, $R = 2f = -60\text{cm}$

Question159

A thin convex lens of focal length ' f ' is put on a plane mirror as shown in the figure. When an object is kept at a distance ' a ' from the lens - mirror combination, its image is formed at a distance $\frac{a}{3}$ in front of the combination. The value of ' a ' is :

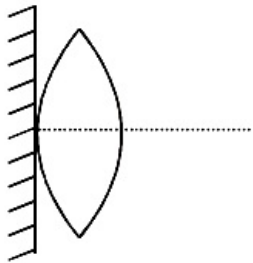

[Online April 11, 2015]

Options:

A. $3f$

B. $\frac{3}{2}f$

C. f

D. $2f$

Answer: D

Solution:

When object is kept at a distance 'a' from thin convex lens

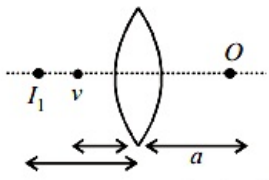

By lens formula : $\frac{1}{v} - \frac{1}{u} = \frac{1}{f}$

$$\frac{1}{V} - \frac{1}{(-a)} = \frac{1}{f}$$

or, $\frac{1}{v} = \frac{1}{f} - \frac{1}{a}$ (i)

Mirror forms image at equal distance from mirror

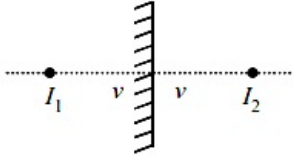

Now, again from lens formula

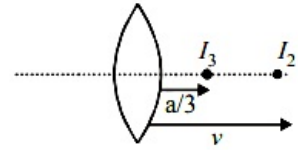

$$\frac{3}{a} - \frac{1}{V} = \frac{1}{f}$$

$$\frac{3}{a} - \frac{1}{f} + \frac{1}{a} = \frac{1}{f} \text{ [From eqn. (i)]}$$

Hence, $a = 2f$

Question 160

Monochromatic light is incident on a glass prism of angle A. If the refractive index of the material of the prism is μ , a ray, incident at an angle θ , on the face AB would get transmitted through the face AC of the prism provided :

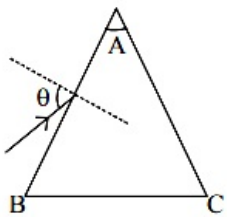

[2015]

Options:

A. $\theta > \cos^{-1} \left[\mu \sin \left(A + \sin^{-1} \left(\frac{1}{\mu} \right) \right) \right]$

B. $\theta < \cos^{-1} \left[\mu \sin \left(A + \sin^{-1} \left(\frac{1}{\mu} \right) \right) \right]$

C. $\theta > \sin^{-1} \left[\mu \sin \left(A - \sin^{-1} \left(\frac{1}{\mu} \right) \right) \right]$

$$D. \theta < \sin^{-1} \left[\mu \sin \left(A - \sin^{-1} \left(\frac{1}{\mu} \right) \right) \right]$$

Answer: C

Solution:

Solution:

When $r_2 = C$, $\angle N_2RC = 90^\circ$

Where $C =$ critical angle

$$\text{As } \sin C = \frac{1}{\mu} = \sin r_2$$

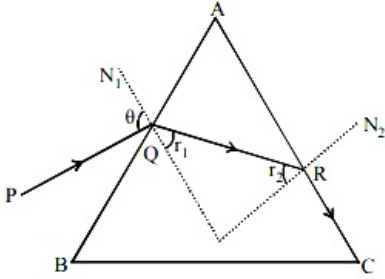

Applying snell's law at 'R'

$$\mu \sin r_2 = 1 \sin 90^\circ \dots\dots(i)$$

Applying snell's law at 'Q'

$$1 \times \sin \theta = \mu \sin r_1 \dots\dots(ii)$$

But $r_1 = A - r_2$

$$\text{So, } \sin \theta = \mu \sin(A - r_2)$$

$$\sin \theta = \mu \sin A \cos r_2 - \cos A \dots\dots(iii) \text{ [using (i)]}$$

From (1)

$$\cos r_2 = \sqrt{1 - \sin^2 r_2} = \sqrt{1 - \frac{1}{\mu^2}} \dots\dots(iv)$$

By eq. (iii) and (iv)

$$\sin \theta = \mu \sin A \sqrt{1 - \frac{1}{\mu^2}} - \cos A$$

on further solving we can show for ray not to be transmitted through face AC

$$\theta = \sin^{-1} \left[\mu \sin \left(A - \sin^{-1} \left(\frac{1}{\mu} \right) \right) \right]$$

So, for transmission through face AC

$$\theta > \sin^{-1} \left[\mu \sin \left(A - \sin^{-1} \left(\frac{1}{\mu} \right) \right) \right]$$

Question161

A telescope has an objective lens of focal length 150 cm and an eyepiece of focal length 5 cm. If a 50 m tall tower at a distance of 1 km is observed through this telescope in normal setting, the angle formed by the image of the tower is θ , then θ is close to :

[Online April 10, 2015]

Options:

A. 30°

B. 15°

C. 60°

D. 1°

Answer: C

Solution:

Mag power of telescope,
$$M P = \frac{\beta \text{ (angle subtended by image at eye piece)}}{\alpha \text{ (angle subtended by object on objective)}}$$

Also,
$$M P = \frac{f_o}{f_e} = \frac{150}{5} = 30$$

$$\alpha = \frac{50}{1000} = \frac{1}{20} \text{ rad}$$

$$\therefore \beta = \theta = M P \times \alpha = 30 \times \frac{1}{20} = \frac{3}{2} = 1.5 \text{ rad}$$

or,
$$\beta = 1.5 \times \frac{180^\circ}{\pi} \approx 84^\circ$$

Question 162

A diver looking up through the water sees the outside world contained in a circular horizon. The refractive index of water is $\frac{4}{3}$, and the diver's eyes are 15cm below the surface of water. Then the radius of the circle is:

[Online April 9, 2014]

Options:

A. $15 \times 3 \times \sqrt{5} \text{ cm}$

B. $15 \times 3\sqrt{7} \text{ cm}$

C. $\frac{15 \times \sqrt{7}}{3} \text{ cm}$

D. $\frac{15 \times 3}{\sqrt{7}} \text{ cm}$

Answer: D

Solution:

Given, $\mu = \frac{4}{3}$

$h = 15 \text{ cm}$

$R = ?$

$\frac{\sin 90^\circ}{\sin C} = \mu$

$$\Rightarrow \sin C = \frac{1}{\mu} = \frac{R}{\sqrt{R^2 + h^2}} = \frac{3}{4}$$

$$\Rightarrow 16R^2 = 9R^2 + 9h^2$$

$$\text{or, } 7R^2 = 9h^2$$

$$\text{or, } R = \frac{3}{\sqrt{7}}h = \frac{3}{\sqrt{7}} \times 15\text{cm}$$

Question163

A thin convex lens made from crown glass ($\mu = \frac{3}{2}$) has focal length f .

When it is measured in two different liquids having refractive indices $\frac{4}{3}$ and $\frac{5}{3}$, it has the focal lengths f_1 and f_2 respectively. The correct relation between the focal lengths is:

[2014]

Options:

A. $f_1 = f_2 < f$

B. $f_1 > f$ and f_2 becomes negative

C. $f_2 > f$ and f_1 becomes negative

D. f_1 and f_2 both become negative

Answer: B

Solution:

Solution:

By Lens maker's formula for convex lens

$$\frac{1}{f} = \left(\frac{\mu}{\mu_L} - 1 \right) \left(\frac{2}{R} \right)$$

$$\text{for, } \mu_{L_1} = \frac{4}{3}, f_1 = 4R$$

$$\text{for } \mu_{L_2} = \frac{5}{3}, f_2 = -5R$$

$$\Rightarrow f_2 = (-) \text{ ve}$$

Question164

The refractive index of the material of a concave lens is μ . It is immersed in a medium of refractive index μ_1 . A parallel beam of light is incident on the lens. The path of the emergent rays when $\mu_1 > \mu$ is:

[Online April 12, 2014]

Options:

A.



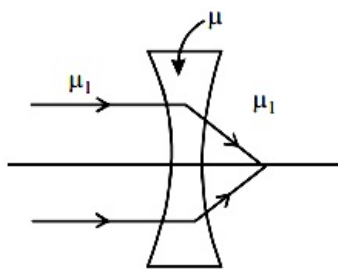

B.

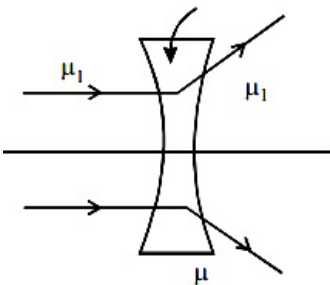

C.

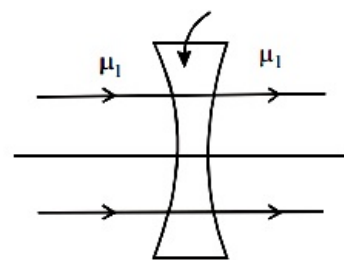

D.

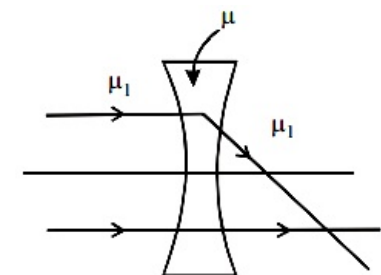

Answer: A

Solution:

Solution:

If a lens of refractive index μ is immersed in a medium of refractive index μ_1 , then its focal length in medium is given by

$$\frac{1}{f_m} = (\mu_1 \mu - 1) \left(\frac{1}{R_1} - \frac{1}{R_2} \right)$$

If f_a is the focal length of lens in air, then

$$\frac{1}{f_a} = (\mu - 1) \left(\frac{1}{R_1} - \frac{1}{R_2} \right)$$

$$\Rightarrow \frac{f_m}{f_a} = \frac{(\mu_1 \mu - 1)}{(\mu - 1)}$$

If $\mu_1 > \mu$, then f_m and f_a have opposite signs and the nature of lens changes i.e. a convex lens diverges the light rays and concave lens converges the light rays. Thus given option (a) is correct.

Question165



An object is located in a fixed position in front of a screen. Sharp image is obtained on the screen for two positions of a thin lens separated by 10 cm. The size of the images in two situations are in the ratio 3 : 2. What is the distance between the screen and the object? [Online April 11, 2014]

Options:

- A. 124.5 cm
- B. 144.5 cm
- C. 65.0 cm
- D. 99.0 cm

Answer: D

Solution:

Solution:

Given: Separation of lens for two of its position, $d = 10\text{cm}$

Ratio of size of the images in two positions

$$\frac{I_1}{I_2} = \frac{3}{2}$$

Distance of object from the screen, $D = ?$

Applying formula,

$$\frac{I_1}{I_2} = \frac{(D + d)^2}{(D - d)^2}$$

$$\Rightarrow \frac{3}{2} = \frac{(D + 10)^2}{(D - 10)^2}$$

$$\Rightarrow \frac{3}{2} = \frac{D^2 + 100 + 20D}{D^2 + 100 - 20D}$$

$$\Rightarrow 3D^2 + 300 - 60D = 2D^2 + 200 + 40D$$

$$\Rightarrow D^2 - 100D + 100 = 0$$

On solving, we get $D = 99\text{cm}$

Hence the distance between the screen and the object is 99cm.

Question166

In a compound microscope, the focal length of objective lens is 1.2 cm and focal length of eye piece is 3.0 cm. When object is kept at 1.25 cm in front of objective, final image is formed at infinity. Magnifying power of the compound microscope should be: [Online April 11, 2014]

Options:

- A. 200
- B. 100
- C. 400
- D. 150

Answer: A



Solution:

Solution:

Given : $f_o = 1.2\text{cm}$; $f_e = 3.0\text{cm}$

$u_o = 1.25\text{cm}$; $M_\infty = ?$

From $\frac{1}{f_o} = \frac{1}{v_o} - \frac{1}{u_o}$

$$\Rightarrow \frac{1}{1.2} = \frac{1}{v_o} - \frac{1}{(-1.25)}$$

$$\Rightarrow \frac{1}{v_o} = \frac{1}{1.2} - \frac{1}{1.25}$$

$$\Rightarrow v_o = 30\text{cm}$$

Magnification at infinity,

$$M_\infty = -\frac{v_o}{u_o} \times \frac{D}{f_e}$$

$$= \frac{30}{1.25} \times \frac{25}{3}$$

($\because D = 25\text{cm}$ least distance of distinct vision) = 200

Hence the magnifying power of the compound microscope is 200

Question167

The focal lengths of objective lens and eye lens of a Galilean telescope are respectively 30 cm and 3.0 cm. telescope produces virtual, erect image of an object situated far away from it at least distance of distinct vision from the eye lens. In this condition, the magnifying power of the Galilean telescope should be:

[Online April 9, 2014]

Options:

A. + 11.2

B. - 11.2

C. - 8.8

D. + 8.8

Answer: D

Solution:

Solution:

Given, Focal length of objective, $f_o = 30\text{cm}$

focal length of eye lens, $f_e = 3.0\text{cm}$

Magnifying power, $M = ?$

Magnifying power of the Galilean telescope,

$$M_D = \frac{f_o}{f_e} \left(1 - \frac{f_e}{D} \right)$$

$$= \frac{30}{3} \left(1 - \frac{3}{25} \right) [\because D = 25\text{cm}]$$

$$= 10 \times \frac{22}{25} = 8.8\text{cm}$$



Question168

A printed page is pressed by a glass of water. The refractive index of the glass and water is 1.5 and 1.33, respectively. If the thickness of the bottom of glass is 1 cm and depth of water is 5 cm, how much the page will appear to be shifted if viewed from the top ?

[Online April 25, 2013]

Options:

- A. 1.033 cm
- B. 3.581 cm
- C. 1.3533 cm
- D. 1.90 cm

Answer: C

Solution:

Solution:

Real depth = 5 cm + 1 cm = 6 cm

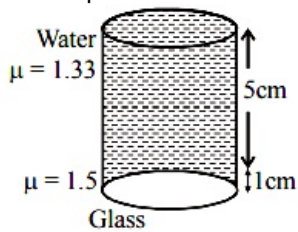

$$\text{Apparent depth} = \frac{d_1}{\mu_1} + \frac{d_2}{\mu_2} + \dots$$

$$= \frac{5}{1.33} + \frac{1}{1.5}$$

$$\approx 3.8 + 0.7 \approx 4.5 \text{ cm}$$

$$\therefore \text{Shift} = 6 \text{ cm} - 4.5 \text{ cm} \approx 1.5 \text{ cm}$$

Question169

A light ray falls on a square glass slab as shown in the diagram. The index of refraction of the glass, if total internal reflection is to occur at the vertical face, is equal to :

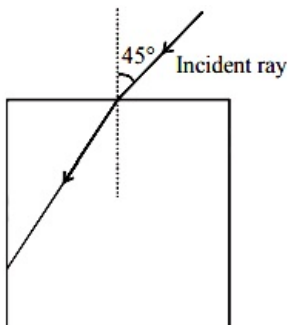

[Online April 23, 2013]

Options:



A. $\frac{(\sqrt{2} + 1)}{2}$

B. $\sqrt{\frac{5}{2}}$

C. $\frac{3}{2}$

D. $\sqrt{\frac{3}{2}}$

Answer: D

Solution:

Solution:

At point A by Snell's law

$$\mu = \frac{\sin 45^\circ}{\sin r} \Rightarrow \sin r = \frac{1}{\mu\sqrt{2}} \dots\dots(i)$$

At point B, for total internal reflection,

$$\sin i_1 = \frac{1}{\mu}$$

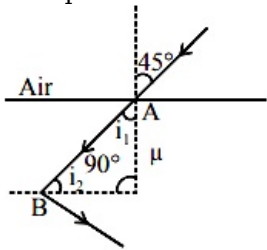

From figure, $i_1 = 90^\circ - r$

$$\therefore (\sin 90^\circ - r) = \frac{1}{\mu}$$

$$\Rightarrow \cos r = \frac{1}{\mu} \dots\dots(ii)$$

$$\text{Now } \cos r = \sqrt{1 - \sin^2 r} = \sqrt{1 - \frac{1}{2\mu^2}}$$

$$= \sqrt{\frac{2\mu^2 - 1}{2\mu^2}} \dots\dots(iii)$$

From eqs (ii) and (iii)

$$\frac{1}{\mu} = \sqrt{\frac{2\mu^2 - 1}{2\mu^2}}$$

Squaring both sides and then solving, we get

$$\mu = \sqrt{\frac{3}{2}}$$

Question 170

Light is incident from a medium into air at two possible angles of incidence (A) 20° and (B) 40° . In the medium light travels 3.0 cm in 0.2 ns. The ray will :
[Online April 9, 2013]

Options:

A. suffer total internal reflection in both cases (A) and (B)

B. suffer total internal reflection in case (B) only

C. have partial reflection and partial transmission in case (B)

D. have 100% transmission in case (A)

Answer: B

Solution:

Solution:

Velocity of light in medium

$$V_{\text{med}} = \frac{3\text{cm}}{0.2\text{ns}} = \frac{3 \times 10^{-2}\text{m}}{0.2 \times 10^{-9}\text{s}} = 1.5\text{m/s}$$

Refractive index of the medium

$$\mu = \frac{V_{\text{air}}}{V_{\text{med}}} = \frac{3 \times 10^8}{1.5} = 2\text{m/s}$$

$$\text{As } \mu = \frac{1}{\sin C}$$

$$\therefore \sin C = \frac{1}{\mu} = \frac{1}{2} = 30^\circ$$

Condition of TIR is angle of incidence i must be greater than critical angle. Hence ray will suffer TIR in case of (B) ($i = 40^\circ > 30^\circ$) only.

Question 171

Diameter of a plano-convex lens is 6 cm and thickness at the centre is 3 mm. If speed of light in material of lens is 2×10^8 m/s, the focal length of the lens is [2013]

Options:

A. 15 cm

B. 20 cm

C. 30 cm

D. 10 cm

Answer: C

Solution:

$$\therefore n = \frac{\text{Velocity of light in vacuum}}{\text{Velocity of light in medium}}$$

$$\therefore n = \frac{3}{2}$$

$$3^2 + (R - 3\text{mm})^2 = R^2$$

$$\Rightarrow 3^2 + R^2 - 2R(3\text{mm}) + (3\text{mm})^2 = R^2$$

$$\Rightarrow R \approx 15\text{cm}$$



$$\frac{1}{f} = \left(\frac{3}{2} - 1\right) \left(\frac{1}{15}\right) \Rightarrow f = 30\text{cm}$$

Question172

The image of an illuminated square is obtained on a screen with the help of a converging lens. The distance of the square from the lens is 40 cm. The area of the image is 9 times that of the square. The focal length of the lens is :

[Online April 22, 2013]

Options:

A. 36 cm

B. 27 cm

C. 60 cm

D. 30 cm

Answer: D

Solution:

Solution:

If side of object square = 1
and side of image square = 1'

From question, $\frac{1'^2}{1} = 9$

or $\frac{1'}{1} = 3$

i.e., magnification $m = 3$

$u = -40\text{cm}$

$v = 3 \times 40 = 120\text{cm}$

$f = ?$

From formula, $\frac{1}{v} - \frac{1}{u} = \frac{1}{f}$

$$\frac{1}{120} - \frac{1}{-40} = \frac{1}{f}$$

$$\text{or, } \frac{1}{f} = \frac{1}{120} + \frac{1}{40} = \frac{1+3}{120} \therefore f = 30\text{cm}$$

Question173

The graph between angle of deviation (δ) and angle of incidence (i) for a triangular prism is represented by [2013]

Options:

A.

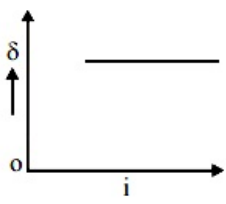

B.

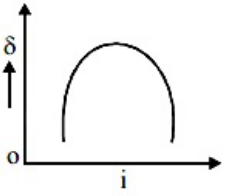

C.

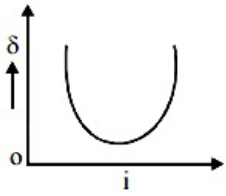

D.

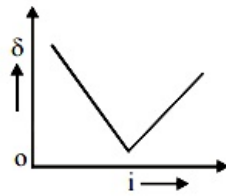

Answer: C

Solution:

Solution:

For the prism as the angle of incidence (i) increases, the angle of deviation (δ) first decreases goes to minimum value and then increases.

Question174

This question has Statement-1 and Statement-2. Of the four choices given after the Statements, choose the one that best describes the two Statements.

Statement 1: Very large size telescopes are reflecting telescopes instead of refracting telescopes.

Statement 2: It is easier to provide mechanical support to large size mirrors than large size lenses.

[Online April 23, 2013]

Options:

A. Statement-1 is true and Statement-2 is false.

B. Statement-1 is false and Statement-2 is true.

C. Statement-1 and statement-2 are true and Statement - 2 is correct explanation for statement-1.

D. Statements-1 and statement-2 are true and Statement-2 is not the correct explanation for statement-1.

Answer: C

Solution:

Solution:

One side of mirror is opaque and another side is reflecting this is not in case of lens hence, it is easier to provide mechanical support to large size mirrors than large size lenses. Reflecting telescopes are based on the same principle except that the formation of images takes place by reflection instead of refraction.

Question175

The focal length of the objective and the eyepiece of a telescope are 50 cm and 5 cm respectively. If the telescope is focussed for distinct vision on a scale distant 2 m from its objective, then its magnifying power will be:

[Online April 22, 2013]

Options:

A. - 4

B. - 8

C. + 8

D. - 2

Answer: D

Solution:

Solution:

Given: $f_o = 50\text{cm}$, $f_e = 5\text{cm}$

$d = 25\text{cm}$, $u_o = -200\text{cm}$

Magnification $M = ?$

$$\text{As } \frac{1}{v_o} - \frac{1}{u_o} = \frac{1}{f_o}$$

$$\Rightarrow \frac{1}{v_o} = \frac{1}{f_o} + \frac{1}{u_o} = \frac{1}{50} - \frac{1}{200} = \frac{4-1}{200} = \frac{3}{200}$$

$$\text{or } v_o = \frac{200}{3}\text{cm}$$

Now $v_e = d = -25\text{cm}$

$$\text{From, } \frac{1}{v_e} - \frac{1}{u_e} = \frac{1}{f_e}$$

$$-\frac{1}{u_e} = \frac{1}{f_e} - \frac{1}{v_e}$$

$$= \frac{1}{5} + \frac{1}{25} = \frac{6}{25}$$

$$\text{or, } v_e = \frac{-25}{6}\text{cm}$$

$$\begin{aligned} \text{Magnification } M &= M_o \times M_e \\ &= \frac{v_o}{u_o} \times \frac{v_e}{u_e} = \frac{-200/3}{200} \times \frac{-25}{-25/6} \\ &= -\frac{1}{3} \times 6 = -2 \end{aligned}$$

Question176

An object at 2.4 m in front of a lens forms a sharp image on a film 12 cm behind the lens. A glass plate 1cm thick, of refractive index 1.50 is interposed between lens and film with its plane faces parallel to film. At what distance (from lens) should object shifted to be in sharp focus of film?

[2012]

Options:

- A. 7.2 m
- B. 2.4 m
- C. 3.2 m
- D. 5.6 m

Answer: D

Solution:

Solution:

The focal length of the lens

$$\begin{aligned} \frac{1}{f} &= \frac{1}{v} - \frac{1}{u} \\ &= \frac{1}{12} + \frac{1}{240} \\ &= \frac{20+1}{240} = \frac{21}{240} \\ f &= \frac{240}{21} \text{cm} \end{aligned}$$

When glass plate is interposed between lens and film, so shift produced will be

$$\text{Shift} = t \left(1 - \frac{1}{\mu} \right)$$

$$1 \left(1 - \frac{1}{3/2} \right) = 1 \times \frac{1}{3}$$

Now image should be form at

$$v' = 12 - \frac{1}{3} = \frac{35}{3} \text{cm}$$

Now the object distance u.

Using lens formula again

$$\begin{aligned} \frac{1}{f} &= \frac{1}{v} - \frac{1}{u} \\ \Rightarrow \frac{1}{u} &= \frac{1}{v} - \frac{1}{f} \\ \Rightarrow \frac{1}{u} &= \frac{3}{35} - \frac{21}{240} = \frac{1}{5} \left[\frac{3}{7} - \frac{21}{48} \right] \\ \Rightarrow \frac{1}{u} &= \frac{1}{5} \left[\frac{48-49}{7 \times 16} \right] \\ \Rightarrow u &= -7 \times 16 \times 5 = -560 \text{cm} = -5.6 \text{m} \end{aligned}$$



Question177

A beam of light consisting of red, green and blue colours is incident on a right-angled prism on face AB. The refractive indices of the material for the above red, green and blue colours are 1.39, 1.44 and 1.47 respectively. A person looking on surface AC of the prism will see

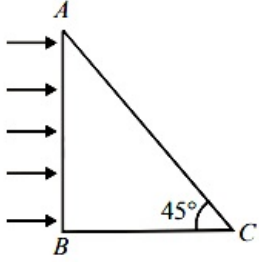

[Online May 26, 2012]

Options:

- A. no light
- B. green and blue colours
- C. red and green colours
- D. red colour only

Answer: D

Solution:

Solution:

For light to come out through face 'AC', total internal reflection must not take place.

i.e., $\theta < c \Rightarrow \sin \theta < \sin c$

$$\Rightarrow \sin \theta < \frac{1}{\mu}$$

$$\text{or } \mu < \frac{1}{\sin \theta} \Rightarrow \mu < \frac{1}{\sin 45^\circ}$$

$$\Rightarrow \mu < \sqrt{2} \Rightarrow \mu < 1.414$$

Question178

A glass prism of refractive index 1.5 is immersed in water (refractive index $\frac{4}{3}$) as shown in figure. A light beam incident normally on the face AB is totally reflected to reach the face BC, if

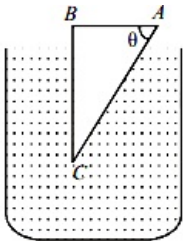

[Online May 19, 2012]

Options:

A. $\sin \theta > \frac{5}{9}$

B. $\sin \theta > \frac{2}{3}$

C. $\sin \theta > \frac{8}{9}$

D. $\sin \theta > \frac{1}{3}$

Answer: C

Solution:

Solution:

For total internal reflection on face AC

$\theta >$ critical angle (C)

and $\sin \theta \geq \sin C$

$$\sin \theta \geq \frac{1}{\mu_g}$$

$$\sin \theta \geq \frac{\mu_w}{\mu_g} \Rightarrow \sin \theta \geq \frac{4}{3}$$

$$\therefore \sin \theta \geq \frac{8}{9}$$

Question 179

Which of the following processes play a part in the formation of a rainbow?

- (i) Refraction**
 - (ii) Total internal reflection**
 - (iii) Dispersion**
 - (iv) Interference**
- [Online May 7, 2012]**

Options:

- A. (i), (ii) and (iii)
- B. (i) and (ii)
- C. (i), (ii) and (iv)
- D. (iii) and (iv)

Answer: A

Solution:

Solution:

Rainbow is formed due to the dispersion of light suffering refraction and total internal reflection (TIR) in the droplets present in the atmosphere

Question180

A telescope of aperture $3 \times 10^{-2}\text{m}$ diameter is focused on a window at 80m distance fitted with a wiremesh of spacing $2 \times 10^{-3}\text{m}$. Given: $\lambda = 5.5 \times 10^{-7}\text{m}$, which of the following is true for observing the mesh through the telescope?
[Online May 26, 2012]

Options:

- A. Yes, it is possible with the same aperture size.
- B. Possible also with an aperture half the present diameter.
- C. No, it is not possible.
- D. Given data is not sufficient.

Answer: A

Solution:

Solution:

Given : $d = 3 \times 10^{-2}\text{m}$

$\lambda = 5.5 \times 10^{-7}\text{m}$

Limit of resolution, $\Delta\theta = \frac{1.22\lambda}{d}$

$$= \frac{1.22 \times 5.5 \times 10^{-7}}{3 \times 10^{-2}} = 2.23 \times 10^{-5}\text{rad}$$

At a distance of 80m, the telescope is able to resolve between two points which are separated by $2.23 \times 10^{-5} \times 80\text{m}$
 $= 1.78 \times 10^{-3}\text{m}$

Question181

We wish to make a microscope with the help of two positive lenses both with a focal length of 20 mm each and the object is positioned 25 mm from the objective lens. How far apart the lenses should be so that the final image is formed at infinity?
[Online May 12, 2012]

Options:

- A. 20 mm
- B. 100 mm
- C. 120 mm
- D. 80 mm

Answer: C

Solution:



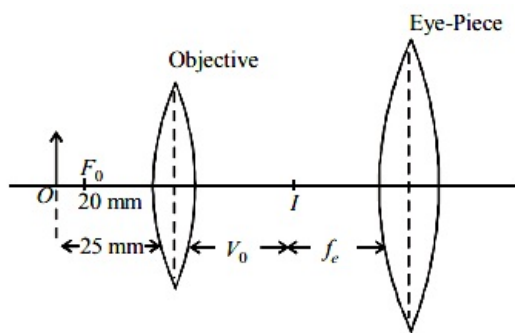

To obtain final image at infinity, object which is the image formed by objective should be at focal distance of eyepiece.

By lens formula (for objective)

$$\frac{1}{v_o} - \frac{1}{u_o} = \frac{1}{f_o}$$

$$\text{or, } \frac{1}{v_o} - \frac{1}{-25} = \frac{1}{20}$$

$$\Rightarrow \frac{1}{v_o} = \frac{1}{20} - \frac{1}{25} = \frac{5-4}{100} = \frac{1}{100} \text{ mm}$$

$$\therefore v_o = 100 \text{ mm}$$

Therefore the distance between the lenses

$$= v_o + f_e = 100 \text{ mm} + 20 \text{ mm} = 120 \text{ mm}$$

Question 182

A car is fitted with a convex side-view mirror of focal length 20 cm. A second car 2.8 m behind the first car is overtaking the first car at a relative speed of 15 m/s. The speed of the image of the second car as seen in the mirror of the first one is :
[2011]

Options:

A. $\frac{1}{15}$ m/s

B. 10 m/s

C. 15 m/s

D. $\frac{1}{10}$ m/s

Answer: A

Solution:

Solution:

From mirror formula

$$\frac{1}{v} + \frac{1}{u} = \frac{1}{f}$$

Differentiating the above equation, we get

$$\frac{dv}{dt} = -\frac{v^2}{u^2} \left(\frac{du}{dt} \right)$$

Also,

$$\frac{v}{u} = \frac{f}{u-f}$$

$$\Rightarrow \frac{dv}{dt} = -\left(\frac{f}{u-f} \right)^2 \frac{du}{dt}$$



$$\Rightarrow \frac{dv}{dt} = \left(\frac{0.2}{2.8 - 0.2} \right)^2 \times 15$$

$$\Rightarrow \frac{dv}{dt} = \frac{1}{15} \text{ m/s}$$

Question 183

Let the $x - z$ plane be the boundary between two transparent media. Medium 1 in $z \geq 0$ has a refractive index of $\sqrt{2}$ and medium 2 with $z < 0$ has a refractive index of $\sqrt{3}$. A ray of light in medium 1 given by the vector $\vec{A} = 6\sqrt{3}\hat{i} + 8\sqrt{3}\hat{j} - 10\hat{k}$ is incident on the plane of separation. The angle of refraction in medium 2 is: [2011]

Options:

- A. 45°
- B. 60°
- C. 75°
- D. 30°

Answer: A

Solution:

Solution:

As refractive index for $z > 0$ and $z \leq 0$ is different xy plane should be the boundary between two media. Angle of incidence is given by

$$\cos(\pi - i) = \frac{(6\sqrt{3}\hat{i} + 8\sqrt{3}\hat{j} - 10\hat{k}) \cdot \hat{k}}{20}$$

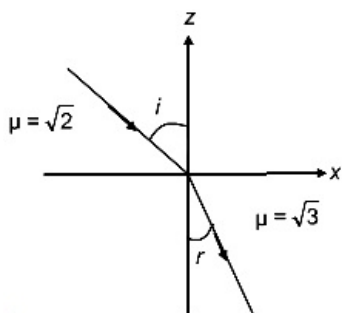

$$-\cos i = -\frac{1}{2}$$

$$\Rightarrow \angle i = 60^\circ$$

From Snell's law, $\mu = \sqrt{2}$

$$\frac{\sin i}{\sin r} = \frac{\mu_2}{\mu_1}$$

$$\Rightarrow \frac{\sin i}{\sin r} = \frac{\sqrt{3}}{\sqrt{2}}$$

$$\Rightarrow \sqrt{2} \sin i = \sqrt{3} \sin r$$

$$\Rightarrow \sqrt{2} \sin 60^\circ = \sqrt{3} \sin r$$

$$\Rightarrow \sqrt{2} \times \frac{\sqrt{3}}{2} = \sqrt{3} \sin r$$

$$\Rightarrow \angle r = 45^\circ$$

Question184

A beaker contains water up to a height h_1 and kerosene of height h_2 above water so that the total height of (water + kerosene) is $(h_1 + h_2)$. Refractive index of water is μ_1 and that of kerosene is μ_2 . The apparent shift in the position of the bottom of the beaker when viewed from above is
[2011 RS]

Options:

A. $\left(1 + \frac{1}{\mu_1}\right)h_1 - \left(1 + \frac{1}{\mu_2}\right)h_2$

B. $\left(1 - \frac{1}{\mu_1}\right)h_1 + \left(1 - \frac{1}{\mu_2}\right)h_2$

C. $\left(1 + \frac{1}{\mu_1}\right)h_2 - \left(1 + \frac{1}{\mu_2}\right)h_1$

D. $\left(1 - \frac{1}{\mu_1}\right)h_2 + \left(1 - \frac{1}{\mu_2}\right)h_1$

Answer: B

Solution:

Solution:

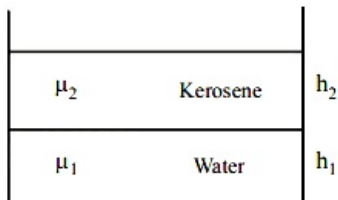

Apparent shift of the bottom due to water,

$$\Delta h_1 = h_1 \left[1 - \frac{1}{\mu_1} \right]$$

Apparent shift of the bottom due to kerosene, Δh_2

$$= h_2 \left[1 - \frac{1}{\mu_2} \right]$$

Thus, total apparent shift :

$$= \Delta h_1 + \Delta h_2$$

$$= \left(1 - \frac{1}{\mu_1}\right)h_1 + \left(1 - \frac{1}{\mu_2}\right)h_2$$

Question185

When monochromatic red light is used instead of blue light in a convex lens, its focal length will
[2011 RS]

Options:

A. increase

- B. decrease
- C. remain same
- D. does not depend on colour of light

Answer: A

Solution:

From the Cauchy

$$= A + \frac{B}{\lambda^2} + \frac{C}{\lambda^1}$$

$$\therefore \mu \propto \frac{1}{\lambda}$$

As, $\lambda_{\text{blue}} < \lambda_{\text{red}}$

$$\therefore \lambda_{\text{blue}} > \mu_{\text{red}}$$

From lens maker's formula

$$\text{and } \frac{1}{f} = (\mu - 1) \left(\frac{1}{R_1} - \frac{1}{R_2} \right)$$

$$\Rightarrow \frac{1}{f_B} > \frac{1}{f_R} \Rightarrow f_R > f_B$$

Question 186

A transparent solid cylindrical rod has a refractive index of $\frac{2}{\sqrt{3}}$. It is surrounded by air. A light ray is incident at the mid-point of one end of the rod as shown in the figure.

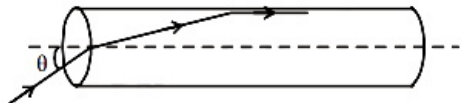

The incident angle θ for which the light ray grazes along the wall of the rod is:

[2009]

Options:

A. $\sin^{-1}(\sqrt{3} / 2)$

B. $\sin^{-1}\left(\frac{2}{\sqrt{3}}\right)$

C. $\sin^{-1}\left(\frac{1}{\sqrt{3}}\right)$

D. $\sin^{-1}(1 / 2)$

Answer: C

Solution:

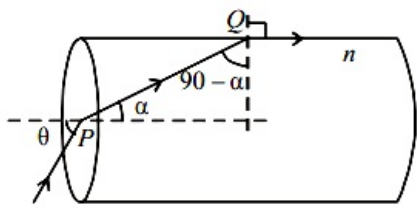

Applying Snell's law for medium inside the cylinder and air at Q we get

$$n = \frac{\sin 90^\circ}{\sin(90^\circ - \alpha)} = \frac{1}{\cos \alpha}$$

$$\therefore \cos \alpha = \frac{1}{n}$$

$$\therefore \sin \alpha = \sqrt{1 - \cos^2 \alpha} = \sqrt{1 - \frac{1}{n^2}} = \frac{\sqrt{n^2 - 1}}{n} \dots\dots(i)$$

Applying Snell's Law for air and medium inside the cylinder at P we get

$$n = \frac{\sin \theta}{\sin \alpha}$$

$$\Rightarrow \sin \theta = n \times \sin \alpha = \sqrt{n^2 - 1}; \text{ [from (i)]}$$

$$\therefore \sin \theta = \sqrt{\left(\frac{2}{\sqrt{3}}\right)^2 - 1} = \sqrt{\frac{4}{3} - 1} = \frac{1}{\sqrt{3}}$$

$$\text{or } \theta = \sin^{-1}\left(\frac{1}{\sqrt{3}}\right)$$

Question 187

In an optics experiment, with the position of the object fixed, a student varies the position of a convex lens and for each position, the screen is adjusted to get a clear image of the object. A graph between the object distance u and the image distance v , from the lens, is plotted using the same scale for the two axes. A straight line passing through the origin and making an angle of 45° with the x-axis meets the experimental curve at P. The coordinates of P will be [2009]

Options:

A. $\left(\frac{f}{2}, \frac{f}{2}\right)$

B. (f, f)

C. $(4f, 4f)$

D. $(2f, 2f)$

Answer: D

Solution:

Solution:

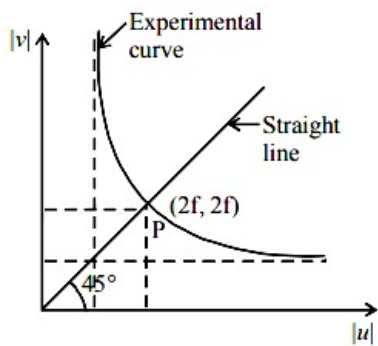

For the graph to intersect $y = x$ line. The value of $|v|$ and $|u|$ must be equal.

From lens formula

$$\frac{1}{v} - \frac{1}{u} = \frac{1}{f}$$

When $u = -2f$, $v = 2f$

$$\text{Also } v = \frac{f}{1 + \frac{f}{u}}$$

As $|u|$ increases, v decreases for $|u| > f$. The graph between $|v|$ and $|u|$ is shown in the figure. A straight line passing through the origin and making an angle of 45° with the X-axis meets the experimental curve at $P(2f, 2f)$.

Question 188

A student measures the focal length of a convex lens by putting an object pin at a distance 'u' from the lens and measuring the distance 'v' of the image pin. The graph between 'u' and 'v' plotted by the student should look like

[2008]

Options:

A.

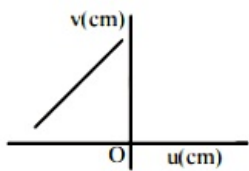

B.

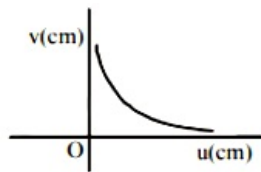

C.

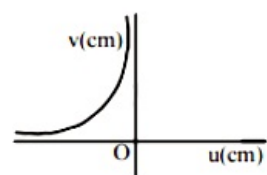

D.

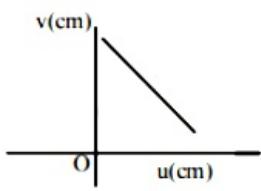

Answer: C

Solution:

Solution:

From the lens formula $\frac{1}{f} = \frac{1}{v} - \frac{1}{u}$

This graph suggest that when

$u = -f, v = +\infty$

When u is at $-\infty, v = f$.

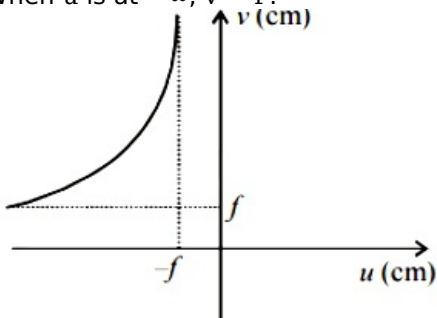

When the object is moved further away from the lens, v decreases but remains positive.

Question 189

An experiment is performed to find the refractive index of glass using a travelling microscope. In this experiment distances are measured by [2008]

Options:

- A. a vernier scale provided on the microscope
- B. a standard laboratory scale
- C. a meter scale provided on the microscope
- D. a screw gauge provided on the microscope

Answer: A

Solution:

Solution:

To find the refractive index of glass using a travelling microscope, a vernier scale is provided on the microscope

Question 190

Two lenses of power -15 D and +5 D are in contact with each other. The

focal length of the combination is [2007]

Options:

- A. + 10 cm
- B. - 20 cm
- C. - 10 cm
- D. + 20 cm

Answer: C

Solution:

Solution:

When two thin lenses are in contact coaxially, power of combination is given by

$$\begin{aligned} P &= P_1 + P_2 \\ &= (-15 + 5)D \\ &= -10D. \end{aligned}$$

$$\text{Also, } P = \frac{1}{f}$$

$$\Rightarrow f = \frac{1}{P} = \frac{1}{-10} \text{ metre}$$

$$\therefore f = -\left(\frac{1}{10} \times 100\right) \text{ cm} = -10 \text{ cm}$$

Question 191

The refractive index of a glass is 1.520 for red light and 1.525 for blue light. Let D_1 and D_2 be angles of minimum deviation for red and blue light respectively in a prism of this glass. Then,
[2006]

Options:

- A. $D_1 < D_2$
- B. $D_1 = D_2$
- C. D_1 can be less than or greater than D_2 depending upon the angle of prism
- D. $D_1 > D_2$

Answer: A

Solution:

Solution:

When angle of prism is small,

Angle of deviation, $D = (\mu - 1)A$

Since $\lambda_b < \lambda_r$

$$\Rightarrow \mu_r < \mu_b \Rightarrow D_1 < D_2$$



Question192

A fish looking up through the water sees the outside world contained in a circular horizon. If the refractive index of water is $\frac{4}{3}$ and the fish is 12cm below the surface, the radius of this circle in cm is [2005]

Options:

- A. $\frac{36}{\sqrt{7}}$
- B. $36\sqrt{7}$
- C. $4\sqrt{5}$
- D. $36\sqrt{5}$

Answer: A

Solution:

Solution:

From the figure it is clear that

$$\tan \theta_c = \frac{AB}{OA}$$

$$\Rightarrow R = OA \tan \theta_c$$

$$\Rightarrow R = \frac{OA \sin \theta_c}{\cos \theta_c}$$

$$\Rightarrow R = \frac{OA \sin \theta_c}{\sqrt{1 - \sin^2 \theta_c}}$$

$$\Rightarrow \tan \theta_c = \frac{R}{12} = \frac{\sin \theta_c}{\sqrt{1 - \sin^2 \theta_c}}$$

$$\therefore \sin \theta_c = \frac{1}{\mu} = \frac{3}{4}$$

$$\Rightarrow \tan \theta_c = \frac{3}{\sqrt{16 - 9}} = \frac{3}{\sqrt{7}} = \frac{R}{12}$$

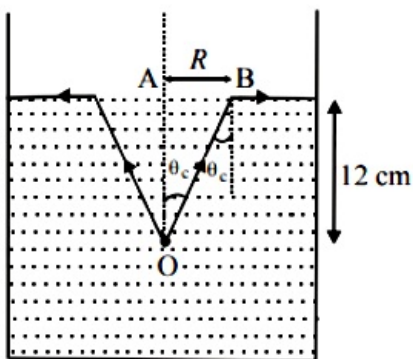

$$\Rightarrow R = \frac{36}{\sqrt{7}} \text{ cm}$$

Question193

A thin glass (refractive index 1.5) lens has optical power of - 5 D in air.

Its optical power in a liquid medium with refractive index 1.6 will be [2005]

Options:

- A. - 1D
- B. 1 D
- C. - 25 D
- D. 25 D

Answer: B

Solution:

Solution:

According to lens maker's formula in air

$$\frac{1}{f_a} = (\mu_g - 1) \left(\frac{1}{R_1} - \frac{1}{R_2} \right)$$

$$\Rightarrow \frac{1}{f_a} = \left(\frac{1.5}{1} - 1 \right) \left(\frac{1}{R_1} - \frac{1}{R_2} \right) \dots\dots(i)$$

Using lens maker's formula in liquid medium,

$$\frac{1}{f_m} = \left(\frac{\mu_g}{\mu_m} - 1 \right) \left(\frac{1}{R_1} - \frac{1}{R_2} \right)$$

$$\Rightarrow \frac{1}{f_m} = \left(\frac{1.5}{1.6} - 1 \right) \left(\frac{1}{R_1} - \frac{1}{R_2} \right) \dots\dots(ii)$$

Dividing (i) by (ii),

$$\frac{f_m}{f_a} = \left(\frac{1.5 - 1}{\frac{1.5}{1.6} - 1} \right) = -8$$

$$P_a = -5 = \frac{1}{f_a}$$

$$\Rightarrow f_a = -\frac{1}{5}$$

$$\Rightarrow f_m = -8 \times f_a = -8 \times -\frac{1}{5} = \frac{8}{5}$$

$$P_m = \frac{\mu}{f_m} = \frac{1.6}{8} \times 5 = 1D$$

Question194

A plano convex lens of refractive index 1.5 and radius of curvature 30 cm. Is silvered at the curved surface. Now this lens has been used to form the image of an object. At what distance from this lens an object be placed in order to have a real image of size of the object [2004]

Options:

- A. 60 cm
- B. 30 cm
- C. 20 cm
- D. 80 cm

Answer: C

Solution:

Solution:

The focal length (F) of the final mirror is

$$\frac{1}{F} = \frac{2}{f_1} + \frac{1}{f_m}$$

Using lens maker's formula

$$\text{Here } \frac{1}{f_1} = (\mu - 1) \left(\frac{1}{R_1} - \frac{1}{R_2} \right)$$

Here, $R_1 = \infty$

$R_2 = 30\text{cm}$

$$= (1.5 - 1) \left[\frac{1}{\infty} - \frac{1}{-30} \right] = \frac{1}{60}$$

$$\therefore \frac{1}{F} = 2 \times \frac{1}{60} + \frac{1}{30/2} = \frac{1}{10}$$

$\therefore F = 10\text{cm}$

Real image will be equal to the size of the object if the object distance

$$u = 2F = 20\text{cm}$$

Question195

A light ray is incident perpendicularly to one face of a 90° prism and is totally internally reflected at the glass-air interface. If the angle of reflection is 45°, we conclude that the refractive index n

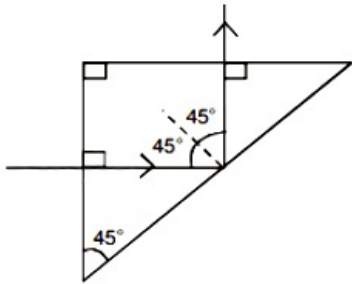

[2004]

Options:

A. $n > \frac{1}{\sqrt{2}}$

B. $n > \sqrt{2}$

C. $n < \frac{1}{\sqrt{2}}$

D. $n < \sqrt{2}$

Answer: B

Solution:

Solution:

For total internal reflection

Incident angle (i) > critical angle (i_c),

$$\therefore \sin i > \sin i_c$$

$$\Rightarrow \sin 45^\circ > \sin i_c \Rightarrow \sin i_c = \frac{1}{n}$$

$$\therefore \sin 45^\circ > \frac{1}{n}$$

$$\Rightarrow \frac{1}{\sqrt{2}} > \frac{1}{n} \Rightarrow n > \sqrt{2}$$

Question 196

To get three images of a single object, one should have two plane mirrors at an angle of [2003]

Options:

- A. 60°
- B. 90°
- C. 120°
- D. 30°

Answer: B

Solution:

Solution:

The number of images formed is given by

$$n = \frac{360}{\theta} - 1$$

$$\Rightarrow \frac{360}{\theta} - 1 = 3$$

$$\Rightarrow \theta = \frac{360^\circ}{4} = 90^\circ$$

Question 197

Consider telecommunication through optical fibres. Which of the following statements is not true? [2003]

Options:

- A. Optical fibres can be of graded refractive index
- B. Optical fibres are subject to electromagnetic interference from outside
- C. Optical fibres have extremely low transmission loss
- D. Optical fibres may have homogeneous core with a suitable cladding.

Answer: B

Solution:

Optical fibres form a dielectric wave guide and are free from electromagnetic interference or radio frequency interference. There is extremely low transmission loss in optical fibre

Question198

The image formed by an objective of a compound microscope is [2003]

Options:

- A. virtual and diminished
- B. real and diminished
- C. real and enlarged
- D. virtual and enlarged

Answer: C

Solution:

Solution:

A real, inverted and enlarged image of the object is formed by the objective lens of a compound microscope.

Question199

If two plane mirrors are kept at 60° to each other, then the number of images formed by them is [2002]

Options:

- A. 5
- B. 6
- C. 7
- D. 8

Answer: A

Solution:

Solution:

When two plane mirrors are inclined at each other at an angle θ then the number of the images (n) of a point object kept between the plane mirrors is

$$n = \frac{360^\circ}{\theta} - 1$$

(if $\frac{360^\circ}{\theta}$ is even integer)

$$\therefore \text{Number of images } d = \frac{360^\circ}{60^\circ} - 1 = 5$$

Question200

**Which of the following is used in optical fibres?
[2002]**

Options:

- A. total internal reflection
- B. scattering
- C. diffraction
- D. refraction.

Answer: A

Solution:

Solution:

In an optical fibre, light is sent through the fibre without any loss by the phenomenon of total internal reflection. Total internal reflection of light waves confine the light rays inside the optical fiber.

Question201

**An astronomical telescope has a large aperture to
[2002]**

Options:

- A. reduce spherical aberration
- B. have high resolution
- C. increase span of observation
- D. have low dispersion

Answer: B

Solution:

Resolving power of a telescope is

$$R.P = \frac{D}{1.22\lambda}$$

where D = diameter of the objective lens

λ = wavelength of light.

$$\text{Clearly, } R.P \propto \frac{D}{\lambda}$$

Resolving power of telescope resolution will be high if its objective is of large aperture.

